

M392C: Covering Spaces of 3-Manifolds

UT Austin, Spring 2011

Alan W. Reid

1 Existence of finite-sheeted covering spaces

For compact 2-manifolds (assume orientable, genus $g \geq 2$, with nonempty boundary and free non-abelian fundamental group), there are lots of finite-sheeted covering spaces that arise from group theory since F_2 surjects onto G , where G is finite and non-abelian.

For this course: All 3-manifolds are connected. All groups are finitely generated. The goal of this section is the following theorem:

Theorem 1.1 (Thurston, Hempel). *Let M be a compact 3-manifold. Then $\pi_1 M$ is residually finite.*

Definition. Let G be a group. G is *residually finite* (RF) if for all $1 \neq g \in G$, there exists a homomorphism $\phi : G \rightarrow A$, with A finite, such that $\phi(g) \neq 1$.

Examples. 1. If G is finite, G is RF.

2. (Exercise) If G is abelian, G is RF.

Remark. With a view to Theorem 1.1, we can assume that $\pi_1 M$ is infinite.

Lemma 1.2. *Let G be a group, and $H < G$ a subgroup. Then*

1. *If G is RF, H is RF.*
2. *If $[G : H] < \infty$ and H is RF, then G is RF.*

Proof. 1. Let $1 \neq h \in H$. If G is RF, there is a homomorphism $\phi : G \rightarrow A$, with A a finite group with $\phi(h) \neq 1$. Letting $\psi = \phi|_H$ shows that H is RF.

2. To prove this, we make the following reformulation.

Claim. *G is RF if and only if for all $1 \neq g \in G$, there is a finite index subgroup $H < G$ such that $g \notin H$.*

Proof. If G is RF, then $\text{Ker } \phi$ is a finite index subgroup of G that excludes g . Let H be a finite index subgroup of G and let $g \in G$ ($g \neq 1$). Take $C = \text{Core}_G(H) = \bigcap (\text{all conjugates of } H)$. Then C is a normal subgroup of finite index in G and $\phi(g) \neq 1$ in G/C . This proves the claim. \square

If $g \in G \setminus H$, this reformulation of RF applies. If $g \in H$ and H is RF, then by the reformulation, there is a finite index subgroup K in H with $g \notin K$. Since $[G : H] < \infty$ and $[H : K] < \infty$, we have that K has finite index in G . \square

Remark. With a view to Theorem 1.1, it suffices to prove residual finiteness on finite covers. In particular, we can assume M is orientable.

We now introduce another reformulation of residual finiteness, which suggests that it corresponds to having “lots” of subgroups of finite index.

Claim. G is RF if and only if $\bigcap_{[G:H]<\infty} H = 1$.

Proof. If G is RF and $g \in \bigcap H$, then by RF, there is a finite index subgroup $K < G$ such that $g \notin K$, a contradiction. If $\bigcap H = 1$ and $g \in G$, then there is some finite index subgroup $H < G$ such that $g \notin H$. \square

The following corollary summarizes the formulations of RF:

Corollary 1.3. *The following are equivalent:*

1. G is RF;
2. For all $g \in G \setminus \{1\}$, there is a finite index subgroup $H < G$ with $g \notin H$;
3. $\bigcap_{[G:H]<\infty} H = 1$.

Remark. If G is RF and $g_1, \dots, g_n \in G \setminus \{1\}$, then there exists a finite index subgroup H of G such that $g_1, \dots, g_n \notin H$. To see this, we intersect the subgroups of G constructed for each g_i .

Topological Reformulations of RF

Let X be a compact topological space and \tilde{X} be its universal cover. Let $G = \pi_1 X$.

What does G RF mean for finite covering spaces of X ?

Let $g \in G$ ($g \neq 1$) and represent g as a based loop $\alpha : I \rightarrow X$. By RF, $g \notin H$. If X_H denotes the cover corresponding to H , then there is some lift of α to X_H that is not a loop. We see the following reformulation of RF in this setting: G is RF if and only if given any based loop $\alpha : I \rightarrow X$, there is a finite sheeted cover $X_1 \rightarrow X$ such that some lift of α is not a loop. (If X_1 is a regular cover, all lifts of α are not loops.)

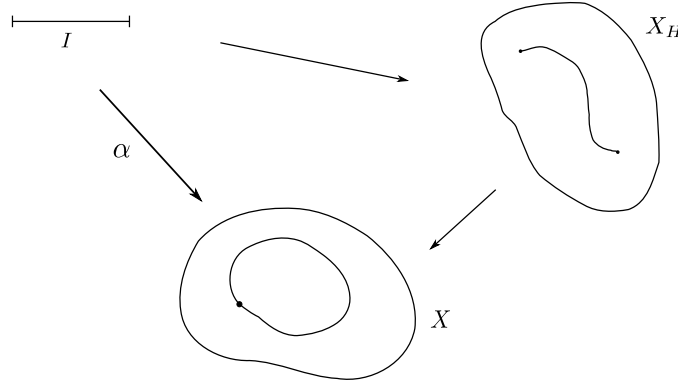

Figure 1.1: X_H is the cover corresponding to the subgroup H

Claim. G is RF if and only if the following condition holds: if C is any compact subset of \tilde{X} , there exists a finite-sheeted covering space $X_C \rightarrow X$ such that under the natural covering map $\tilde{X} \rightarrow X_C$, C projects homeomorphically.

Proof. Since G acts properly discontinuously on \tilde{X} and C is compact, the set $\{g \in G \setminus \{1\} \mid g(C) \cap C \neq \emptyset\}$ is finite. Let $g_1, \dots, g_n \in G$ be the nontrivial elements in this set. By the previous remark, there is a finite index subgroup $H < G$ such that $g_1, \dots, g_n \notin H$. Let $X_H \rightarrow X$ be the finite cover corresponding to H . Then C projects homeomorphically to X_H .

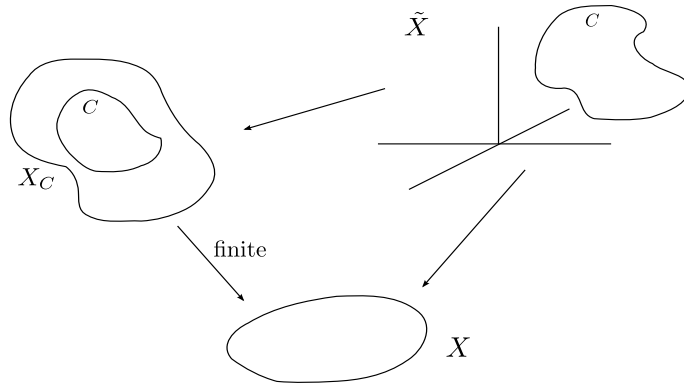

Figure 1.2: C projects homeomorphically to the finite cover X_C

Assume the topological condition holds. Use part 1. Let $g \in G \setminus \{1\}$ and let $\alpha : I \rightarrow X$ be a based loop representing g . By the topological condition, there is a finite sheeted cover $X_C \rightarrow X$ for which C embeds. Then α does not lift to X_C by covering space theory and map lifting. \square

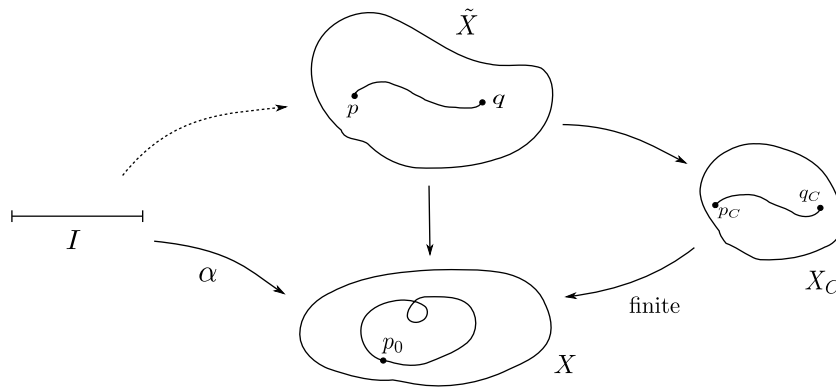

Figure 1.3: The arc $[p, q]$ embeds into the finite cover X_C

Theorem 1.4. *Let F be a finitely generated free group. Then F is RF.*

Proof. The exercise above shows this for abelian groups, so we may assume F is free non-abelian. By Lemma 1.2, it suffices to take F to be the free group of rank 2, i.e. $F = \langle a, b \mid - \rangle$. View F as the fundamental group of a wedge of 2 circles, with one circle colored red and one circle colored blue.

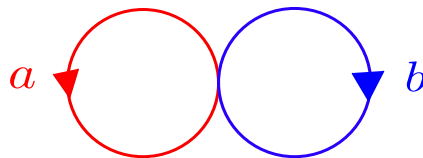

Figure 1.4: View F as the fundamental group of the wedge of two circles X

At each vertex $v \in \tilde{X}$, we see an incoming and outgoing red edge and an incoming and outgoing blue edge. Also recall that to construct a cover of X , it suffices to arrange the local picture at each vertex.

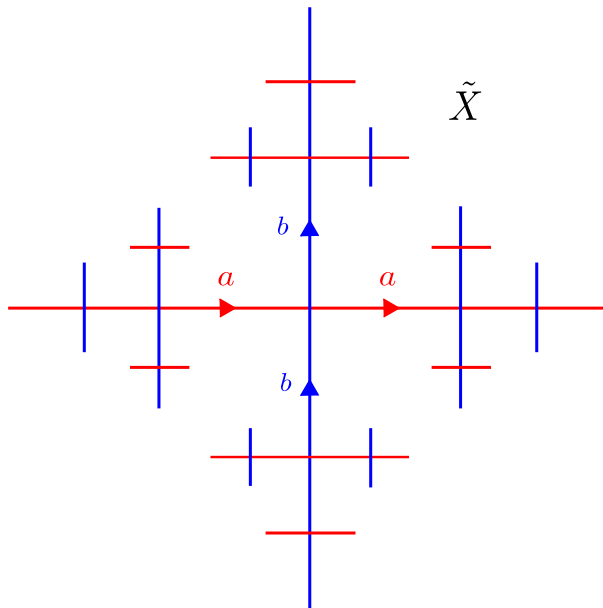

Figure 1.5: The universal cover \tilde{X} of the wedge of two circles

Let $C \subset \tilde{X}$ be compact. (We can assume C is connected.) Let C have k vertices, and edges of C are labeled Red and Blue. If we consider an edge of C labeled Red (respectively, Blue) connecting vertices u and v , one of u and v will be an incoming Red vertex (respectively, outgoing Red vertex).

Let k_* be the number of $*$ edges, where $*$ is Red or Blue. The number of vertices of C missing an incoming or outgoing Red edge is $k - k_R$, and the number of vertices of C missing an incoming or outgoing Blue edge is $k - k_B$. Take a bijection between the two sets of cardinality $k - k_R$. Use this to adjoin the edges to complete a graph on the Red edges. Similarly for the Blue vertices. This determines a finite cover of X because the local conditions hold. \square

Example. Let C be the subset of \tilde{X} given in figure 1.6. Here $k = 8$, and there are $k_R = 3$ red edges and

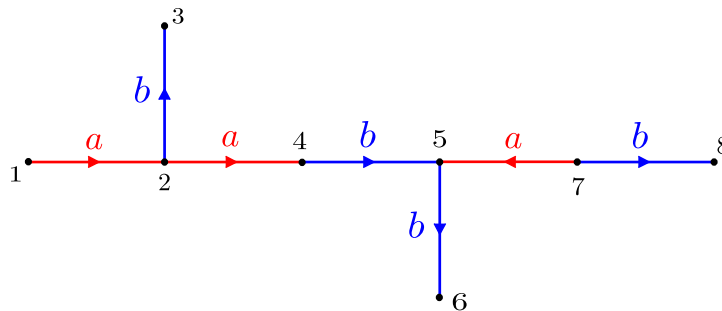

Figure 1.6: A compact subset $C \subset \tilde{X}$

$k_B = 4$ blue edges. The set of vertices lacking an incoming red edge is $\{1, 3, 6, 7, 8\}$, and the set lacking an outgoing red edge is $\{3, 4, 5, 6, 8\}$. We construct a bijection between them by pairing 3, 6 and 8 with

themselves, and pairing 1 with 4, and 7 with 5. In the diagram, this means adding extra red edges with the prescribed endpoints so that the “local picture” is recreated for red edges at each vertex.

Having done this, we now repeat the process for blue edges. The set lacking an incoming edge is $\{1, 2, 4, 7\}$, and the set lacking an outgoing edge is $\{1, 3, 6, 8\}$. We construct the appropriate bijection by pairing 1 with itself, 2 with 3, 4 with 6, and 7 with 8. The resulting graph is shown in figure 1.7.

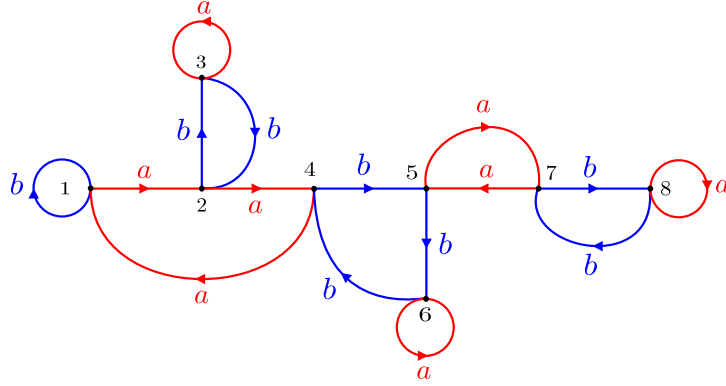

Figure 1.7: The set C , completed with respect to red and blue edges

Completing C with respect to red and blue edges gives a compact subset of \tilde{X} with the correct local picture at each vertex. This then defines a finite cover X_C of X .

Remarks. 1. If G is RF, G has a positive solution to the word problem.

Let $G = \langle X \mid R \rangle$. The word problem asks whether there is an algorithm to decide whether a given word $w \in X$ represents the identity. If G is RF, we can distinguish $g \neq 1$ in G from the identity in some finite quotient, so the word problem is equivalent to listing finite quotients.

2. If M is a closed manifold, one can ask: when does M admit degree 1 maps $M \rightarrow M$ that are not homeomorphisms?

Definition. We say G is *Hopfian* if, whenever $\phi : G \rightarrow G$ is onto, then ϕ is an isomorphism.

Claim. *If the finitely generated group G is RF, then G is Hopfian.*

Proof. Assume $\phi : G \rightarrow G$ is onto and let $K = \ker \phi$. Because G is finitely generated, for all $n \geq 1$, there are only finitely many subgroups of index n in G . Call these subgroups H_1, \dots, H_{k_n} . By the Correspondence Theorem, $\phi^{-1}(H_i)$ is a subgroup of index n . Moreover, the Correspondence Theorem implies that $\{\phi^{-1}(H_i) : i = 1, \dots, k_n\} = \{H_i : i = 1, \dots, k_n\}$ and $K \subset \phi^{-1}(H_i)$ for $i = 1, \dots, k_n$. Then K is contained in every subgroup of finite index in G . Since G is RF, this intersection is trivial, so K is trivial. \square

Proposition 1.5. *There exist finitely presented, non-residually finite groups.*

Proof. Let $B = \langle a, b \mid a^{-1}b^2a = b^3 \rangle$. The task is to exhibit some $w \in B$ ($w \neq 1$) so that the image of w is trivial in all finite quotients of B . Let G be a finite quotient of B and α and β the images in G of a and b , respectively. We need the following facts, which will be presented without proof:

F1. (Consequence of the relation) $a^{-n}b^{2^n}a^n = b^{3^n}$

F2. Let $b_1 = a^{-1}ba$ and $c = b_1^{-1}b^{-1}b_1b$. Combinatorial group theory gives that $c \neq 1$ in B .

Claim (A). *c is trivial in all finite quotients of B .*

Proof. Let α have order n in G . From F1, we see $\beta^{2^n} = \beta^{3^n}$, so $\beta^{3^n} - \beta^{2^n} = 1$, so the order of β divides $3^n - 2^n$. In particular, it is coprime to both 2 and 3. Then β is a power of β^2 . If β_1 is the image of b_1 , then β_1 is a power of β_1^2 . \square

Claim (B). β_1 is a power of β^3 .

Proof. $\beta_1^2 = (\alpha^{-1}\beta\alpha)^2 = \alpha^{-1}\beta^2\alpha = \beta^3$. \square

Then the image of c is $\beta_1^{-1}\beta^{-1}\beta_1\beta = \beta^{-3t}\beta^{-1}\beta\beta^{3t} = 1$. \square

Theorem 1.6. *If G and H are RF, then $G * H$ is RF.*

Proof. Let $1 \neq g \in G * H$. Then g has a normal form, i.e. it has a unique expression $g = g_1h_1 \cdots g_nh_n$, where $g_i \in G$, $h_i \in H$ and, $g_i, h_i \neq 1$. (A similar argument will apply for the variations of this normal form beginning and ending in G or H .) By the extension to RF, there exist homomorphisms $\phi : G \rightarrow A$, $\psi : H \rightarrow B$, where A and B are finite groups and $a_i = \phi(g_i) \neq 1$, $b_i = \psi(h_i) \neq 1$ for $i = 1, \dots, n$. Then there is a homomorphism $\theta : G * H \rightarrow A * B$ where $\theta(g) = a_1b_1 \cdots a_nb_n \neq 1$. Then it suffices to prove the following lemma:

Lemma 1.7. *If A, B are finite groups, then $A * B$ is RF.*

Proof. We will show that $A * B$ is virtually free, i.e. $A * B$ contains a free group of finite index. Let $\phi : A * B \rightarrow A \times B$ be the canonical homomorphism. If $K = \ker \phi$ and A and B are finite, then K is of finite index in $A * B$.

Claim. K is free.

Proof. Use the Kurosh Subgroup Theorem: Suppose that G is the free product of G_1 and G_2 and H is a subgroup of G . Then H is a free product of a free group together with subgroups conjugate into G_1 and subgroups conjugate into G_2 . Apply this to K : $K = F * (*_{\alpha}A_{\alpha}) * (*_{\beta}B_{\beta})$, where A_{α} is conjugate into A and B_{β} is conjugate into B . Since A_{α} is conjugate into A , $\phi(A_{\alpha})$ is conjugate into $\phi(A) = A \times 1$, and since B_{β} is conjugate into B , $\phi(B_{\beta})$ is conjugate into $\phi(B) = 1 \times B$. A_{α} and B_{β} map trivially, so $A_{\alpha} = 1$ and $B_{\beta} = 1$. Then K is free. \square

Definition. G is linear if G admits a faithful representation into $\text{GL}_n(\mathbb{C})$ for some n .

Theorem 1.8. *Finitely generated linear groups are RF.*

Proof. Warm-up: $\text{GL}_n(\mathbb{Z})$.

Let $1 \neq g \in \text{GL}_n(\mathbb{Z})$. Then $g - 1 \neq 0$. Let x be a non-zero entry of $g - 1$. Let $p \in \mathbb{Z}$ be a prime not dividing x . We have a ring homomorphism $\mathbb{Z} \rightarrow \mathbb{Z}/p\mathbb{Z}$ that defines $\phi_p : \text{GL}_n(\mathbb{Z}) \rightarrow \text{GL}_n(\mathbb{Z}/p\mathbb{Z})$. Because $\mathbb{Z}/p\mathbb{Z}$ is a finite group, $\text{GL}_n(\mathbb{Z}/p\mathbb{Z})$ is a finite field. By construction $\phi_p(g) \neq 1$.

Now consider the general case: $g \in \text{GL}_n(\mathbb{C})$ ($g \neq 1$). Assume $G = \langle g_1, \dots, g_n \rangle$. Define R ($\subseteq \mathbb{C}$) to be the ring generated over \mathbb{Z} by 1, entries of g_i , and entries of g_i^{-1} . R is a finitely generated integral domain.

By Lemma 1.2, it suffices to prove RF for $\text{GL}_n(\mathbb{R})$. As before, $g \in \text{GL}_n(\mathbb{R})$ ($g \neq 1$), so $g - 1 \neq 0$ and we can find x , a non-zero entry of $g - 1$. The key algebraic lemma that allows us to extend the argument is the following:

Lemma 1.9. *Let R be a finitely generated integral domain. Then*

$$1. \quad \bigcap_{\mathcal{M} \text{ maximal in } R} \mathcal{M} = (0)$$

2. R/\mathcal{M} is finite field for \mathcal{M} a maximal ideal.

From the first part of the lemma, we can find \mathcal{M} , a maximal ideal such that $x \notin \mathcal{M}$ and proceed as before. \square

Examples. 1. If G is finite, then G is linear: Because G is finite, there is a one-to-one injection of G into S_n for some n . Then use the permutation representation of $S_n \rightarrow \text{GL}_n(\mathbb{C})$.

2. If G and H are linear, the $G \times H$ is linear: If $G \hookrightarrow \text{GL}_n(\mathbb{C})$ and $H \hookrightarrow \text{GL}_m(\mathbb{C})$, then $G \times H$ maps into $\text{GL}_{n+m}(\mathbb{C})$ in the natural way.

3. (Harder) If G and H are linear, then $G * H$ is linear.

Question. If M is compact 3-manifold, is $\pi_1 M$ linear?

Theorem 1.10. Finitely generated free groups are linear.

Proof. \mathbb{Z} is linear. If G is linear and H is a subgroup of G , then H is linear. Then it suffices to show $G = F_2$ is linear. We will use the Ping Pong Lemma.

Theorem (Ping Pong Lemma). Let G act on a set X and $G = \langle A, B \rangle$, where $|A| \geq 3$. Assume that there exist subsets $Y, Z \subset X$ such that

1. $Y \cap Z = \emptyset$;
2. $a(Y) \subset Z$ for all $1 \neq a \in A$ and $b(Z) \subset Y$ for all $1 \neq b \in B$.

Then $G \cong A * B$.

[Window on Ping Pong Lemma]

Proof. There is a natural epimorphism: $f : A * B \rightarrow G$. So we need to show that f is injective. We will do this by showing $\ker f$ is trivial.

Let $a_i \in A$ and $b_j \in B$. If $g \in G \setminus \{1\}$, then

$$g = \left\{ \begin{array}{ll} a_1 b_1 \dots a_{n-1} b_{n-1} a_n & \text{(case 1)} \\ a_1 b_1 \dots a_{n-1} b_{n-1} a_n b_n & \text{(case 2)} \\ b_1 \dots b_{n-1} a_{n-1} b_n & \text{(case 3)} \\ b_1 \dots b_{n-1} a_{n-1} b_n a_n & \text{(case 4)} \end{array} \right\}.$$

Case 1: $a_1 b_1 \dots a_{n-1} b_{n-1} a_n(Y) \subset a_1 b_1 \dots a_{n-1} b_{n-1}(Z) \dots \subset a_1(Y) \subset Z$. Since $Y \cap Z = \emptyset$, $a_1 b_1 \dots a_{n-1} b_{n-1} a_n$ is non-trivial.

Case 2: Consider $a_1 b_1 \dots a_{n-1} b_{n-1} a_n b_n$. Since $|A| \geq 3$, there is an $a \in A \setminus \{1, a_1\}$. Now, $g = a^{-1} a_1 b_1 \dots a_{n-1} b_{n-1} a_n b_n a$ fits into case 1. Thus, g is non-trivial and $a_1 b_1 \dots a_{n-1} b_{n-1} a_n b_n$ is also non-trivial.

Case 3: This case follows from conjugation by $a_0 \in A \setminus \{1\}$. $a_0 b_1 \dots a_n b_n a_0^{-1}$. We now have reduced the problem to case 1.

Case 4: This case follows from considering $(a_1 b_1 \dots a_{n-1} b_{n-1} a_n b_n)^{-1}$, which is non-trivial by case 2. \square

Now let $\alpha, \beta \in \mathbb{C}$, with $|\alpha|, |\beta| \geq 2$. Let $A = \left\langle \begin{pmatrix} 1 & \alpha \\ 0 & 1 \end{pmatrix} \right\rangle \cong \mathbb{Z}$ and $B = \left\langle \begin{pmatrix} 1 & 0 \\ \beta & 1 \end{pmatrix} \right\rangle \cong \mathbb{Z}$. Then we have $G = \langle A, B \rangle \subset \text{SL}_2(\mathbb{C})$. We view $\text{SL}_2(\mathbb{C})$ as acting on \mathbb{C}^2 by $\begin{pmatrix} a & b \\ c & d \end{pmatrix} \begin{pmatrix} z \\ w \end{pmatrix} = \begin{pmatrix} az + bw \\ cz + dw \end{pmatrix}$. We let $Y = \{(z, w) : |z| < |w|\}$ and $Z = \{(z, w) : |z| > |w|\}$.

Clearly, $Y \cap Z = \emptyset$. We check the second condition of the Ping Pong Lemma. Let $\lambda \in \mathbb{C}$. Then $\begin{pmatrix} 1 & \lambda \\ 0 & 1 \end{pmatrix} \begin{pmatrix} z \\ w \end{pmatrix} = \begin{pmatrix} z + \lambda w \\ w \end{pmatrix}$. If $|\lambda| \geq 2$ and $(z, w) \in Y$, then $|z + \lambda w| > |w|$, i.e. the image is in Z . Then $a(Y) \subset Z$ for all $1 \neq a \in A$. The same argument shows $b(Z) \subset Y$ for all $1 \neq b \in B$. \square

Remark. Free groups are everywhere in linear groups. More precisely, let Γ be a finitely generated linear group, then either Γ contains a free non-abelian group or Γ is *virtually solvable*. This is known as the *Tits Alternative*.

Example. Linear groups with a view to geometry.

1. Euclidean manifolds

Let $\mathbb{E}^n = (\mathbb{R}^n, d_{\mathbb{E}})$. Then $\text{Isom}(\mathbb{E}^n) = \{x \mapsto Ax + b \mid A \in O(n), b \in \mathbb{R}^n\}$. We can exhibit a linear map of $\text{Isom}(\mathbb{E}^n)$. Here multiplication in $\text{Isom}(\mathbb{E}^n)$ is just composition:

$$\begin{aligned} x &\xrightarrow{g} Ax + b \\ x &\xrightarrow{h} A'x + b' \\ (g \circ h)(x) &= g(h(x)) \\ &= A(A'x + b') + b \\ &= (AA')x + (Ab' + b) \end{aligned} .$$

We can exhibit a linear representation of $\text{Isom}(\mathbb{E}^n)$:

$$g \mapsto \left[\begin{array}{c|c} A & b \\ \hline 0 & 1 \end{array} \right] \in \text{GL}_{n+1}(\mathbb{R})$$

Hence, $\text{Isom}(\mathbb{E}^n)$ is linear.

[Window: this metric on \mathbb{R}^{n+1} restricts to a Euclidean metric]

Definition. M is called a *Euclidean (or flat)* manifold if $M = \mathbb{E}^n/\Gamma$ and $\Gamma \subset \text{Isom}(\mathbb{E}^n)$ acts freely and discontinuously.

If Γ is finitely generated, then Γ is residually finite by Theorem 1.8.

Remarks. 1. It follows from Bieberbach's Theorem 1 that if M^n is a closed flat manifold, then $\pi_1 M$ has \mathbb{Z}^n as a finite index subgroup.

2. It follows from Bieberbach's Theorem 2 that for a fixed n , there are only finitely many closed, flat n -manifolds distinct up to homeomorphism.

Question. *Are there flat manifolds that are integral homology spheres?*

2. Hyperbolic Manifolds

A Riemannian manifold M is *hyperbolic* if $M = \mathbb{H}^n/\Gamma$ where $\Gamma \subset \text{Isom}(\mathbb{H}^n)$ acts freely and discontinuously. The upper half-space model for hyperbolic n -space is $\mathbb{H}^n = \{(x_1, \dots, x_n) \in \mathbb{R}^n \mid x_n > 0\}$ with a metric defined by

$$ds^2 = \frac{dx_1^2 + dx_2^2 + \dots + dx_n^2}{x_n^2} = \frac{\text{"Euclidean metric"}^2}{\text{height}^2}.$$

Claim. $\text{Isom}(\mathbb{H}^n)$ is linear.

The proof is hard to show in the upper half-space model in high dimensions. However, it is relatively easy to see in the hyperboloid model. First equip \mathbb{R}^{n+1} with an inner product $\langle \cdot, \cdot \rangle$ where

$$\langle x, y \rangle = x_1y_1 + \dots + x_ny_n - x_{n+1}y_{n+1}.$$

Let $\mathbb{H}^n = \{x \in \mathbb{R}^{n+1} \mid \langle x, x \rangle = -1, x_{n+1} > 0\}$ be the "upper sheet" of the hyperboloid. We can define a metric d on \mathbb{H}^n by $\cosh(d(x, y)) = \langle x, y \rangle$.

[See Window for proof that d is a metric]

Definition. $O_0(n, 1) = \{X \in GL_{n+1}(\mathbb{R}) \mid X^T J X = J, X \text{ preserves sheets}\}$, where

$$J = \begin{pmatrix} 1 & 0 & \dots & 0 \\ 0 & \ddots & 0 & \vdots \\ \vdots & 0 & 1 & 0 \\ 0 & \dots & 0 & -1 \end{pmatrix}.$$

By the definition, $O_0(n, 1) \subset \text{Isom}(\mathbb{H}^n)$. In fact, $O_0(n, 1) = \text{Isom}(\mathbb{H}^n)$.

[See Window for more details]

The upshot of the above is that if M is hyperbolic and $\pi_1 M$ is finitely generated, then $\pi_1 M$ is residually finite.

Proposition 1.11. *Let Σ_g be a closed orientable surface of genus $g \geq 1$. Then $\pi_1 \Sigma_g$ is linear (and hence RF, by Theorem 1.8).*

Proof. If $g = 1$, then $\pi_1 \Sigma_g$ is abelian and is linear as shown before. It suffices to show the case where $g = 2$, because all other Σ_g cover Σ_2 .

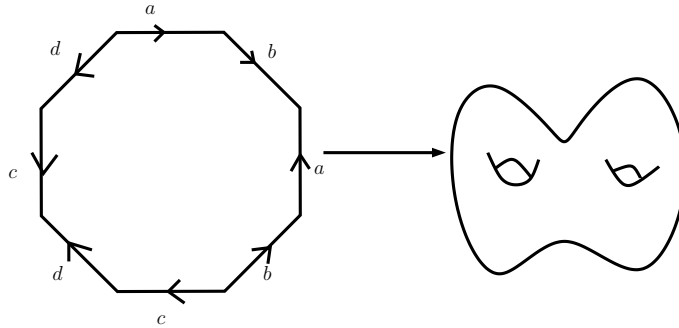

Figure 1.8: The identification of the octagon will be shown to be \mathbb{H}^2/Γ , where Γ is linear.

Topologically, Σ_2 is an identification space of an octagon. To show that Σ_2 is a hyperbolic manifold, we need a faithful representation $\rho : \pi_1 \Sigma_2 \rightarrow \text{Isom}(\mathbb{H}^2)$ with $\rho(\pi_1 \Sigma_2)$ acting freely and discontinuously. The following steps achieve this:

1. Build a hyperbolic octagon;
2. Glue sides together by isometries of \mathbb{H}^2 ;
3. Insist that interior angles are $\frac{\pi}{4}$. ($\frac{8\pi}{4} = 2\pi$).

Geodesics in (the upper half-plane model for) \mathbb{H}^2 are straight lines and circles orthogonal to $\partial\mathbb{H}^2 = \mathbb{R} \cup \{\infty\}$. The octagon should be built from sides contained in such geodesics. (Note that we can always find these isometries: given a pair C_1, C_2 of circles or lines as above there is a $T \in \text{PSL}_2(\mathbb{R})$ that sends C_1 to C_2).

Denoting the four pictured side-pairings by $A, B, C, D \in \text{PSL}_2(\mathbb{R})$, then $\langle A, B, C, D \rangle \subset \text{Isom}(\mathbb{H}^2)$, and $\langle A, B, C, D \rangle \cong \pi_1(\Sigma_2)$.

Notice from Figure 1.9 that all eight vertices of the octagon are identified in the quotient. We thus require a regular octagon with angles $\frac{2\pi}{8} = \frac{\pi}{4}$. Thurston gives an elegant way to do this via uniformly growing a small, almost Euclidean octagon to a larger octagon with arbitrarily small angles, and appealing to the Intermediate Value Theorem. We will build the required octagon from smaller triangles.

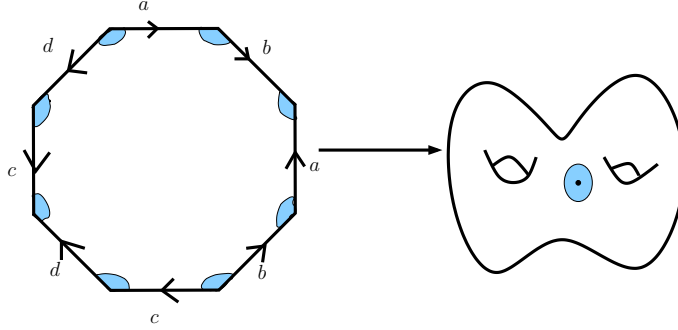

Figure 1.9: Here, we enforce a condition like the manifold condition, be we do it metrically.

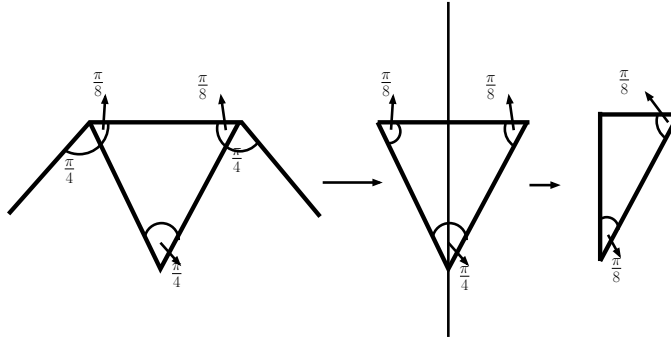

Figure 1.10: The smallest triangle we need to make.

As seen in Figure 1.10, we have to construct a triangle in \mathbb{H}^2 with interior angles $(\frac{\pi}{2}, \frac{\pi}{8}, \frac{\pi}{8})$. To construct this triangle, let L be the vertical geodesic with endpoints at 0 and ∞ in the upper half-plane. Let C be any geodesic meeting L orthogonally, so C lies on a circle centered at 0 . Elementary analysis then gives a circle C' , centered on the real axis, which meets L and C such that the resulting triangle has interior angles as required (Figure 1.11).

Thus $\pi_1 \Sigma_2$ can be realized in $\text{PSL}_2(\mathbb{R})$, and hence is linear. \square

Having shown that surface groups are RF, we return to the proof of Theorem 1.1 for 3-manifolds. Let M^3 be a compact, (connected), orientable 3-manifold. Our next reduction will be that we will only have to consider closed 3-manifolds.

Example. Let $H_g =$ handlebody of genus $g \geq 1$.

The boundary $\partial H_g = \Sigma_g$ is the surface of genus g . If $i : \partial H_g \rightarrow H_g$ is the inclusion map, then i_* is not injective at the level of fundamental group. For example, if C is the given curve (Figure 1.12), then $i_*([C]) = 1$.

For simplicity, we will only worry about embeddings of orientable surfaces.

Definition. Let Σ be a closed, orientable surface. Let M^3 be a 3-manifold and let $f : \Sigma \hookrightarrow M$ be an embedding.

1. If $\Sigma \neq S^2$, then (the image of) Σ is *incompressible* if $f_* : \pi_1 \Sigma \rightarrow \pi_1 M$ is injective.
2. If $\Sigma = S^2$, then (the image of) Σ is *incompressible* if Σ does not bound a 3-ball in M .

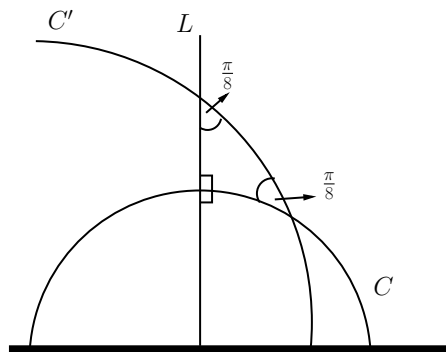

Figure 1.11: C meets L at angle $\frac{\pi}{2}$.

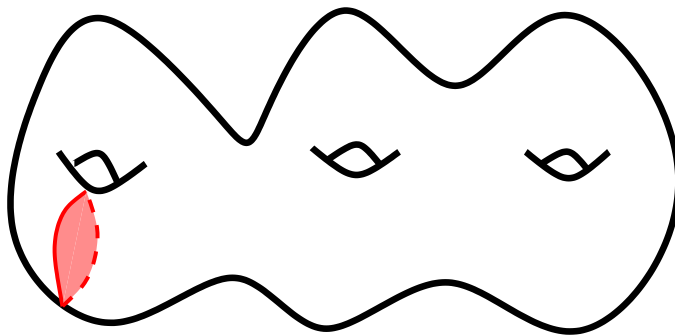

Figure 1.12: H_g .

Otherwise, Σ is *compressible*.

The above definition relies on the fundamental group. In fact, it is equivalent to the geometric definition by the following theorems that connect the algebra to the topology.

Theorem (Loop Theorem, Papakyriakopoulos, 1956). *Let M be an orientable 3-manifold. Let $f : S \hookrightarrow M$ be an embedding of a closed orientable surface. Then if $\ker f_* \neq 1$, there is an essential simple closed curve on S that lies in $\ker f_*$, i.e. there is a disk $D \subset M$ such that $D \cap S = \partial D$ is essential simple closed curve on S .*

Recall that an *essential* curve γ on S is non-trivial in $\pi_1(S)$ and bounds an embedded disk in M .

Definition. M^3 is *irreducible* if for every embedding $f : S^2 \hookrightarrow M$, the image $f(S)$ is compressible (that is, every sphere in M bounds a ball).

Theorem (Alexander's Theorem). \mathbb{R}^3 and \mathbb{S}^3 are *irreducible*.

Examples. 1. Let M_1, M_2 be closed, oriented 3-manifolds. Form the connect sum of M_1 and M_2 , denoted by $M_1 \# M_2$, as follows. Let $B_i \subset M_i$ ($i = 1, 2$) be a 3-ball. Remove the interiors of the B_i . Form the quotient space obtained by identifying $\partial B_i = \partial B_2 \cong S^2$ by a homeomorphism of S^2 such that $M_1 \# M_2$ is orientable.

If $M_1, M_2 \neq S^3$, then the identification sphere is an incompressible S^2 in $M_1 \# M_2$.

2. Let $M^3 = \mathbb{H}^3/\Gamma$ be closed and orientable. Then M is irreducible and every embedding $T^2 \hookrightarrow M$ of the 2-torus into M compresses.

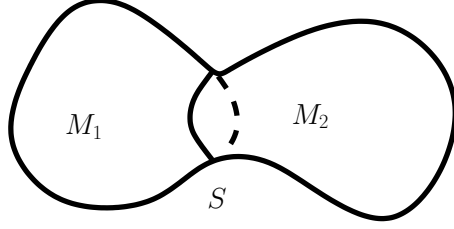

Figure 1.13: The connect sum of two 3-manifolds

Proof. To prove the irreducibility, we will prove the following:

Claim. *Suppose $p : \mathbb{R}^3 \rightarrow M$ is the universal cover. Then M is irreducible.*

This statement is purely topological, so we may apply it to $M = \mathbb{H}^3/\Gamma$.

Proof. Assume that $S \subset M$ is a 2-sphere. S lifts to \mathbb{R}^3 to give a collection of S^2 's in \mathbb{R}^3 that are just translates of each under the action of $\pi_1 M$. By Alexander's theorem, all of these S^2 's bound balls in \mathbb{R}^3 . Choose a particular lift, \tilde{S} such that the ball B it bounds contains no other lifts of S . (We may do this because Γ acts discontinuously action on \mathbb{R}^3).

Claim. *S bounds $p(B)$.*

Proof. First check that $p : B \rightarrow p(B)$ is a covering map. Then since $\tilde{S} \rightarrow S$ is injective, it follows that p is a homeomorphism onto its image. \square

We now need to show that every $T^2 \hookrightarrow M$ compresses. We shall show that $\mathbb{Z} \oplus \mathbb{Z} \not\subset \Gamma$. Let $P = \langle \alpha, \beta \rangle \subset \Gamma$ be a copy of $\mathbb{Z} \oplus \mathbb{Z}$. Recall $\text{Isom}^+(\mathbb{H}^3) = \text{PSL}_2(\mathbb{C})$, with action is the natural extension of

$$\begin{pmatrix} a & b \\ c & d \end{pmatrix} \cdot z = \frac{az + b}{cz + d}.$$

Non-trivial elements of $\text{PSL}_2(\mathbb{C})$ are characterized as follows:

1. γ is elliptic: there exists a fixed point inside \mathbb{H}^3 . In this case, γ is conjugate in $\text{PSL}_2(\mathbb{C})$ to $\begin{pmatrix} \lambda & 0 \\ 0 & \lambda^{-1} \end{pmatrix}$, where $|\lambda| = 1$.
2. γ is hyperbolic: there are two fixed points in the boundary of \mathbb{H}^3 . In this case, γ is conjugate in $\text{PSL}_2(\mathbb{C})$ to $\begin{pmatrix} \lambda & 0 \\ 0 & \lambda^{-1} \end{pmatrix}$, where $|\lambda| \neq 1$.
3. γ is parabolic: there is exactly one fixed point in the boundary of \mathbb{H}^3 . In this case, γ is conjugate in $\text{PSL}_2(\mathbb{C})$ to $\begin{pmatrix} 1 & 1 \\ 0 & 1 \end{pmatrix}$.

First, note that since M is a manifold, Γ does not contain non-trivial elements of finite order. Neither can it contain elliptic elements of infinite order, since they would cause Γ to not be discrete. Thus, α and β are not elliptic.

Assume that α is hyperbolic. Conjugate Γ in $\text{PSL}_2(\mathbb{C})$ so that $\alpha = \begin{pmatrix} \lambda & 0 \\ 0 & \lambda^{-1} \end{pmatrix}$. Then α has fixed points $\{0, \infty\}$. Let A be the geodesic in \mathbb{H}^3 from 0 to ∞ . If $\beta = \begin{pmatrix} a & b \\ c & d \end{pmatrix}$ and $[\alpha, \beta] = 1$, where $[\ , \]$ is the commutator, then

$$\begin{pmatrix} \lambda & 0 \\ 0 & \lambda^{-1} \end{pmatrix} \begin{pmatrix} a & b \\ c & d \end{pmatrix} = \begin{pmatrix} \lambda a & \lambda b \\ \lambda^{-1} c & \lambda^{-1} d \end{pmatrix}$$

and

$$\begin{pmatrix} a & b \\ c & d \end{pmatrix} \begin{pmatrix} \lambda & 0 \\ 0 & \lambda^{-1} \end{pmatrix} = \begin{pmatrix} \lambda a & \lambda^{-1} b \\ \lambda c & \lambda^{-1} d \end{pmatrix}.$$

We see $\lambda b = b\lambda^{-1}$ and $\lambda c = c\lambda^{-1}$, so either $\lambda = \lambda^{-1}$ or $c = b = 0$. By assumption, $\lambda \neq \lambda^{-1}$, and therefore β fixes both 0 and ∞ . $P = \langle \alpha, \beta \rangle \subset \Gamma$ acts freely and discontinuously on \mathbb{H}^3 , so $P|_A$ acts freely and discontinuously on A . But this is a contradiction, as such a group is isomorphic to \mathbb{Z} .

Now suppose that α, β are parabolic elements. Conjugate in $\mathrm{PSL}_2(\mathbb{C})$ such that $\alpha = \begin{pmatrix} 1 & 1 \\ 0 & 1 \end{pmatrix}$ and $\beta = \begin{pmatrix} 1 & x \\ 0 & 1 \end{pmatrix}$.

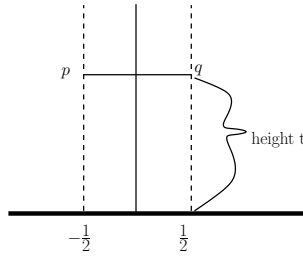

Figure 1.14: The hyperbolic distance between p and q is $\frac{1}{t}$.

Let p and $q = \alpha(p)$ be two points of equal height t identified by α . The hyperbolic distance between p and q is $\frac{1}{t}$ (see Figure 1.14). As p and q move upwards toward ∞ , the hyperbolic distance $d_{\mathbb{H}}(p, q) = \frac{1}{t}$ goes to 0. But diameter is bounded in the Riemannian manifold M . So in M we see a sequences of closed geodesics whose lengths converge to 0, which is illegal. \square

\square

Example. Let $K \subset S^3$ be a non-trivial knot. Denote by $V = N(K)$ a tubular neighborhood of K , and by

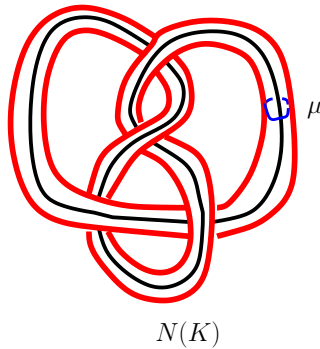

Figure 1.15: A neighborhood of a non-trivial knot.

$E(K) := S^3 \setminus \text{int}(N(K))$ the exterior of K . Note that $E(K)$ is compact 3-manifold with torus boundary.

Claim. $T = \partial V$ is incompressible in $E(K)$.

Definition. A *meridian* μ of K is an essential simple closed curve on ∂V such that bounds a disk in V .

We want to (canonically) choose a second essential simple closed curve on ∂V such that $\langle \mu, \lambda \rangle = \pi_1 T = H_1(T, \mathbb{Z})$. Furthermore, we ask that λ be such that the intersection number $\lambda \cdot \mu = 1$, and that λ is homologically trivial in $H_1(E(K), \mathbb{Z})$. Recall from Mayer-Vietoris $H_1(T) = H_1(V) \oplus H_1(E(K))$. We choose λ to be a generator for $H_1(V)$, trivial in $H_1(E(K))$, and such that $\lambda \subset \partial V$ is a simple closed curve homologous to K in V . We call such a λ a (*preferred*) *longitude* for K .

Proof of Claim (T is incompressible). Assume that T is compressible. By The Loop Theorem, there is a disk $D \subset E(K)$ such that $D \cap T = \partial D = \ell$ is an essential simple closed curve on T . Since ℓ is homotopically trivial in $E(K)$, ℓ is homologically trivial in $E(K)$. Hence $\ell = \lambda$ (the preferred longitude). Now we have that λ co-bounds an annulus with K , and ℓ bounds a disk. Hence, K bounds a disk. This contradicts K being non-trivial. \square

Example. Let K_1, K_2 non-trivial knots, and $E(K_1), E(K_2)$ their exteriors. Form a new manifold $E(K_1) \cup_T E(K_2)$ where $T = T^2 \cong \partial E(K_1) \cong \partial E(K_2)$. By the above claim, T is an incompressible torus in M . (These are examples of the classes of manifolds with fundamental groups that are not known to admit linear representations.)

We now return to the proof of Theorem 1.1. It suffices to prove the theorem for closed 3-manifolds, as illustrated by the following result.

Proposition 1.12. *If all closed 3-manifolds are residually finite, then all 3-manifolds are residually finite.*

Proof. Let $\partial M \neq \emptyset$. Assume ∂M consists of finitely many closed orientable surfaces. We may also suppose that there are no S^2 boundary components, because capping these off would leave these with 3-balls would leave the fundamental group unchanged.

Case 1: All boundary components of M are incompressible.

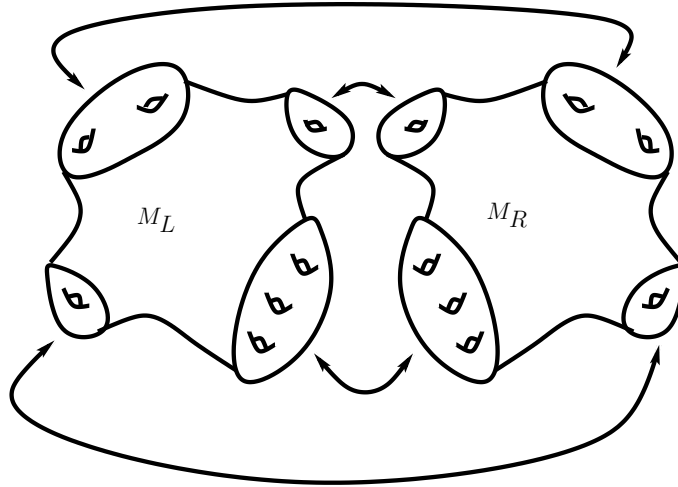

Figure 1.16: The manifold D_M

Let D_M be the closed orientable 3-manifold formed by identifying the boundary components of M_R and M_L in $M_L \cup M_R$ (see Figure 1.16). The fundamental group $\pi_1 D_M$ is obtained from $\pi_1 M$ by a sequence of amalgamations and HNN extensions. Furthermore, $\pi_1(M)$ injects at each stage by the Seifert-van Kampen theorem. Therefore if $\pi_1(D_M)$ is residually finite, then $\pi_1(M)$ is residually finite.

Case 2: Some boundary component Σ of M compresses.

By the Loop Theorem, there is an essential simple closed curve $c \in \Sigma$ that bounds a disk in M . Hence, the proof of the proposition is completed by the following lemma.

Lemma 1.13. *Let M be as above. Then there exist 3-manifolds M_1, \dots, M_n such that $\pi_1(M) = \pi_1(M_1) * \pi_1(M_2) * \dots * \pi_1(M_n) * F$, where the M_i have incompressible boundary, and F is free.*

The proof of this is left to the reader (cf. HW)

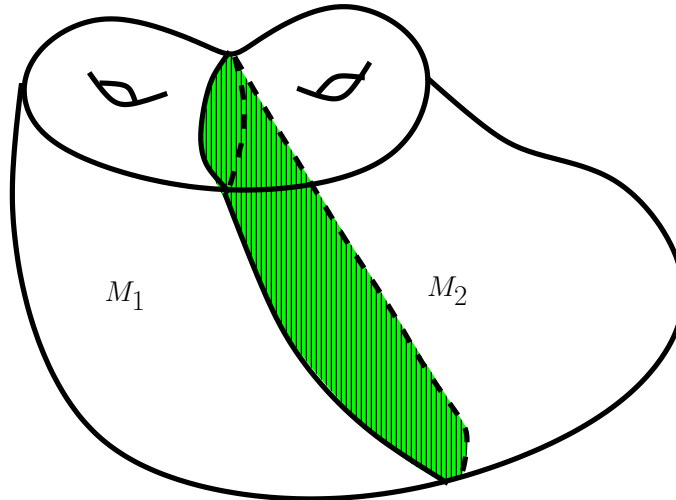

Figure 1.17: Here Σ is compressible.

Hence, from Case 1 and before $\pi_1(M)$ is residually finite if each of the $\pi_1(M_i)$ are residually finite. \square

Definition. M is *prime* if whenever $M = M_1 \# M_2$, then at least one of the $M_i \cong S^3$.

Example. $S^2 \times S^1$ is not irreducible (it has an incompressible S^2) but is prime.

Example. (see hw 1) If M is closed, orientable, and prime but not irreducible then $M \cong S^2 \times S^1$.

Proof. (sketch) That M contains incompressible S^2 and is prime implies that the incompressible S^2 , say S , is nonseparating. We argue that M contains an $S^2 \times S^1$ as a connect summand contradicting, M being prime. To do this take a neighborhood $S^2 \times I$ about S and drawing in an arc (see Figure 1.18). We can show that this gives $S^2 \times S^1$ as a summand. \square

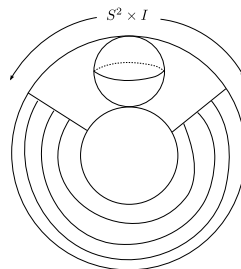

Figure 1.18: M contains an incompressible, non-separating S^2

Remark. If M is not prime, then $\pi_1 M$ is a free product.

Theorem (Prime Decomposition Theorem (Kneser, Milnor)). *Let M be a closed orientable 3-manifold. Then M contains a collection of pairwise disjoint, incompressible S^2 's such that decomposing M along the spheres gives a collection of prime 3-manifolds (Kneser). This is unique up to the order of prime factors (Milnor).*

Remark. This collection may be empty.

Now, to prove Theorem 1.1, it is enough to assume M is closed, orientable and prime.

Theorem (Geometrization Conjecture (version 1)). *Let M be as above. Then M contains a family \mathcal{T} of pairwise disjoint, incompressible tori such that the interior of any component of $M \setminus \mathcal{T}$ admits a “geometric structure of finite volume” (or $\pi_1(\text{cpt})$ is virtually abelian).*

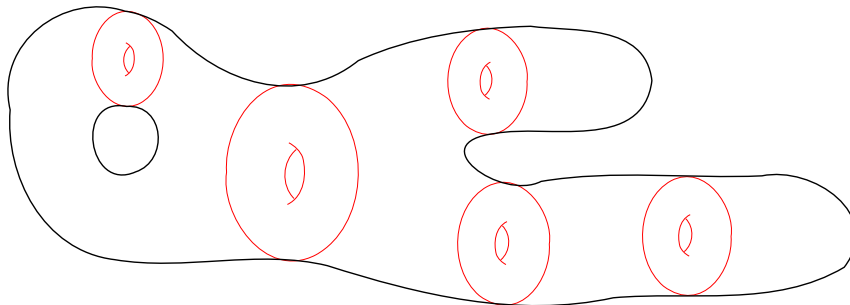

Figure 1.19: An example of a JSJ decomposition \mathcal{T}

Examples. 1. $M = \mathbb{H}^3/\Gamma$ ($T = \emptyset$), and $M = \mathbb{S}^3/\Gamma$ ($T = \emptyset$).

2. Two nontrivial knot exteriors, say the figure 8 knot and the trefoil, glued along their torus boundary.

3. $M = T^3$ – cutting along a T^2 we get a $T^2 \times I$.

Geometric Manifolds

Let X^n be a Riemannian manifold. X^n is called *homogenous* if $\text{Isom}(X^n)$ acts transitively on X .

Definition. By an *n -dimensional geometry* we mean a connected, simply connected, homogenous Riemannian manifold X such that X is *unimodular* (i.e. X has a quotient space of finite volume). We say that the Riemannian manifold M admits a *geometric structure modelled on X* if $M = X/\Gamma$ with $\Gamma \subset \text{Isom}(X)$ acting freely and discontinuously.

Example. ($n = 2$)

1. S^2 is compact so itself has finite volume;
2. \mathbb{E}^2 has the group $\mathbb{Z} \times \mathbb{Z}$ acting discretely and discontinuously, with compact quotient;
3. \mathbb{H}^2 has the genus g surface Σ_g as a quotient, for $g \geq 2$.

Example. ($n = 3$)

1. S^3 is compact so itself has finite volume;

2. \mathbb{E}^3 has \mathbb{Z}^3 acting discretely and discontinuously, with compact quotient the 3-torus T^3 ;
3. \mathbb{H}^3 has finite volume quotients, one is constructed below.

Example. (arbitrary n)

1. S^n is compact so itself has finite volume;
2. \mathbb{E}^n is acted on by \mathbb{Z}^n with compact quotient the n -torus T^n ;
3. \mathbb{H}^n is a more difficult case, and was shown to have an n -dimensional geometry by work of Borel, who showed these have cocompact lattices.

Example. To show \mathbb{H}^3 is a 3-dimensional geometry, use the Seifert-Weber dodecahedral space. Start with a dodecahedron in \mathbb{H}^3 with all dihedral angles equal to $\frac{2\pi}{5}$ (See Figure 1.20) and identify opposite faces with a $\frac{3\pi}{5}$ clockwise twist. The result is a closed hyperbolic 3-manifold.

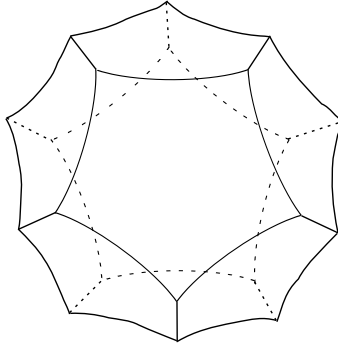

Figure 1.20: A regular dodecahedron in \mathbb{H}^3

Examples. (Other 3-dimensional geometries)

1. $S^2 \times \mathbb{R}$ with the product metric. $\text{Isom}(S^2 \times \mathbb{R}) = \text{Isom}(S^2) \times \text{Isom}(\mathbb{R})$, so $S^2 \times S^1$ is a finite volume quotient of $S^2 \times \mathbb{R}$ by \mathbb{Z} .
2. $\mathbb{H}^2 \times \mathbb{R}$ with the product metric. In a similar way, $\Sigma_g \times S^1$ is a finite volume quotient, for $g \geq 2$.

Example. $\text{NIL} = \left\{ \begin{pmatrix} 1 & x & z \\ 0 & 1 & y \\ 0 & 0 & 1 \end{pmatrix} \mid x, y, z \in \mathbb{R} \right\}$.

This is a 3-dimensional Lie group: it is a closed subgroup of $\text{SL}_2(\mathbb{R})$. It is connected and simply connected. To see this, we can identify NIL with \mathbb{R}^3 so that multiplication is preserved.

Since we have the multiplication rule

$$\begin{pmatrix} 1 & x & z \\ 0 & 1 & y \\ 0 & 0 & 1 \end{pmatrix} \begin{pmatrix} 1 & x' & z' \\ 0 & 1 & y' \\ 0 & 0 & 1 \end{pmatrix} = \begin{pmatrix} 1 & x+x' & z+z'+xy' \\ 0 & 1 & y+y' \\ 0 & 0 & 1 \end{pmatrix},$$

we can define a multiplication in \mathbb{R}^3 by

$$(x, y, z)(x', y', z') = (x+x', y+y', z+z'+xy')$$

and identify the element $\begin{pmatrix} 1 & x & z \\ 0 & 1 & y \\ 0 & 0 & 1 \end{pmatrix} \in \text{NIL}$ with $(x, y, z) \in \mathbb{R}^3$.

NIL, being a Lie group, admits a Riemannian metric which is left invariant under NIL, i.e. there is a map $L_a : \text{NIL} \rightarrow \text{NIL}$ defined by $L_a(y) = ay$ (see Scott's article for explicit coordinates). Also, $\text{NIL} \subset \text{Isom}(\text{NIL})$. Note that NIL acts transitively and freely on itself, since NIL is a group.

To show NIL is a 3-dimensional geometry, consider $H = \left\{ \begin{pmatrix} 1 & x & z \\ 0 & 1 & y \\ 0 & 0 & 1 \end{pmatrix} \mid x, y, z \in \mathbb{Z} \right\} \subset \text{NIL}$. H acts freely on NIL. Since \mathbb{Z} is a discrete subgroup of \mathbb{R} , H is a discrete subgroup of NIL, and, since H is discrete, H acts discontinuously on NIL.

Claim: NIL/H is a closed 3-manifold.

Proof. Let $a = \begin{pmatrix} 1 & 1 & 0 \\ 0 & 1 & 0 \\ 0 & 0 & 1 \end{pmatrix}$ and $b = \begin{pmatrix} 1 & 0 & 0 \\ 0 & 1 & 1 \\ 0 & 0 & 1 \end{pmatrix}$. Clearly $\langle a, b \rangle \subset H$. We show that $H = \langle a, b \rangle$.

Let $c = aba^{-1}b^{-1} = \begin{pmatrix} 1 & 0 & 1 \\ 0 & 1 & 0 \\ 0 & 0 & 1 \end{pmatrix}$. It suffices to write $g = \begin{pmatrix} 1 & x & z \\ 0 & 1 & y \\ 0 & 0 & 1 \end{pmatrix} \in H$ in terms of a, b, c .

We have

$$a^n = \begin{pmatrix} 1 & n & 0 \\ 0 & 1 & 0 \\ 0 & 0 & 1 \end{pmatrix}, \quad b^m = \begin{pmatrix} 1 & 0 & 0 \\ 0 & 1 & m \\ 0 & 0 & 1 \end{pmatrix}, \quad c^k = \begin{pmatrix} 1 & 0 & k \\ 0 & 1 & 0 \\ 0 & 0 & 1 \end{pmatrix}$$

and so

$$a^n b^m c^k = \begin{pmatrix} 1 & n & k + nm \\ 0 & 1 & m \\ 0 & 0 & 1 \end{pmatrix}.$$

Given g we can solve the equations $n = x$, $m = y$, $k = z - xy$. Therefore $H = \langle a, b \rangle$.

We now seek to describe the quotient space NIL/H .

Remarks. 1. One checks that $[a, c] = 1$ and $[b, c] = 1$.

2. We have $\langle b, c \rangle \subset H$, generating a copy of $\langle b, c \rangle \cong \mathbb{Z} \oplus \mathbb{Z} \subset H$. Now a normalizes $\langle b, c \rangle$, because, since $aba^{-1}b^{-1} = c$, we have $aba^{-1} = cb$. Furthermore, $[a, c] = 1$, so we have $\langle b, c \rangle \triangleleft H$. So H has a normal subgroup isomorphic to $\mathbb{Z} \oplus \mathbb{Z}$.

3. Notice that $\langle b, c \rangle$ acts by unit translations:

$$(0, 1, 0) \cdot (x, y, z) = (x, y + 1, z)$$

and

$$(0, 0, 1) \cdot (x, y, z) = (x, y, z + 1).$$

4. Consider $T^3 = \mathbb{R}^3/\Lambda$ with $\Lambda = \langle A, B, C \rangle$ where A, B, C are translations:

$$A : \underline{x} \mapsto \underline{x} + \begin{pmatrix} 1 \\ 0 \\ 0 \end{pmatrix}, \quad B : \underline{x} \mapsto \underline{x} + \begin{pmatrix} 0 \\ 1 \\ 0 \end{pmatrix}, \quad C : \underline{x} \mapsto \underline{x} + \begin{pmatrix} 0 \\ 0 \\ 1 \end{pmatrix}.$$

Now $\langle B, C \rangle$ acts on the (y, z) -plane in the same way as NIL above. Consider $\mathbb{R}^3/\langle B, C \rangle \cong \mathbb{R} \times T^2$ (see Figure 1.21). Taking the quotient of $\mathbb{R} \times T^2$ by A identifies $T^2 \times \{0\}$ with $T^2 \times \{1\}$, giving T^3 .

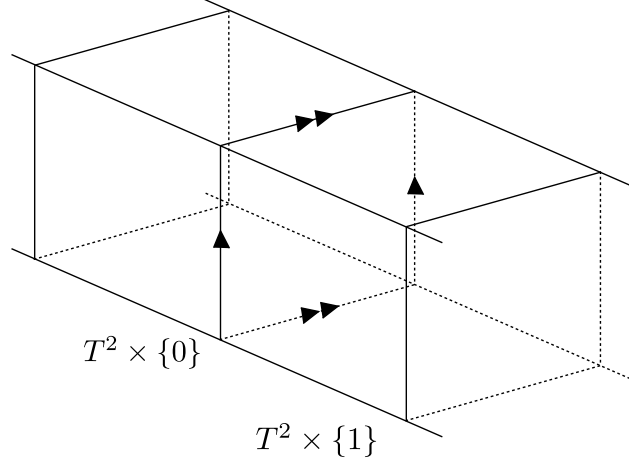

Figure 1.21: $T^2 \times \mathbb{R}$, before identification

To describe NIL/H , we first form the quotient $\mathbb{R} \times T^2$ by quotienting out by $\langle b, c \rangle$. This is the same as in the above remark, because $\langle b, c \rangle$ acts on \mathbb{R}^3 in the same way as $\langle B, C \rangle$. To see how a acts, notice that

$$(1, 0, 0) \cdot (x, y, z) = (x + 1, y, z + y),$$

so (x, y, z) gets identified with $(x + 1, y, z + y)$ by a , and $T^2 \times \{0\}$ gets identified with $T^2 \times \{1\}$ with a twist. This shows NIL/H is a closed 3-manifold (so NIL has a 3-geometric structure), proving the Claim. \square

We can alternatively think of NIL/H in the following way: Let

$$T = \begin{pmatrix} 1 & 0 \\ 1 & 1 \end{pmatrix},$$

acting on $\mathbb{R}^2 = (y, z)$ plane via $T : (y, z) \mapsto (y, y + z)$. The action of T preserves the standard \mathbb{Z} -lattice, so T descends to a homeomorphism $\varphi : T^2 \rightarrow T^2$. To get a different description of the previous construction, take $T^2 \times I / \sim$ where $(x, 0) \sim (\varphi(x), 1)$.

We next describe another 3-dimensional geometry, SOL , whose construction bears some similarity to the above.

Let $A = \begin{pmatrix} 2 & 1 \\ 1 & 1 \end{pmatrix}$. As above, A descends to a self-homeomorphism of T^2 . The eigenvalues of A are

$$\lambda = \frac{3 + \sqrt{5}}{2} := e^{t_0}$$

and

$$\lambda^{-1} = \frac{3 - \sqrt{5}}{2} = e^{-t_0}.$$

The corresponding eigenvectors are

$$v_1 = \begin{pmatrix} \frac{1+\sqrt{3}}{2} \\ 1 \end{pmatrix}, \quad v_2 = \begin{pmatrix} \frac{1-\sqrt{3}}{2} \\ 1 \end{pmatrix}.$$

Powers of A act by expanding in v_1 and by contracting in v_2 . Identifying $\{v_1, v_2\} \leftrightarrow \{e_1, e_2\}$, then A acts by $(x, y) \mapsto (e^{t_0}x, e^{-t_0}y)$.

To describe SOL, we equip \mathbb{R}^3 with another multiplication,

$$(x, y, z)(z', y'z') = (x + e^z x', y + e^{-z} y', z + z'),$$

and the metric $ds^2 = e^{2z} dx^2 + e^{-2z} dy^2 + dz^2$. Note that with this multiplication, we have another plane preserved by a normal subgroup: $\mathbb{R}^2 = \{(x, y, 0)\} \triangleleft \mathbb{R}^3$. Define a group of isometries as follows: B and C will be the unit translations in the x and y directions respectively, and $\psi : (x, y, z) \mapsto (e^{t_0} x, e^{-t_0} y, z + t_0)$. $\langle B, C \rangle$ preserves the $(x, y) \times \{0\}$ plane. Form $\mathbb{R}^3 / \langle B, C, \psi \rangle = T^2 \times I / \sim$ where $(x, 0) \sim (\psi(x), 1)$, and ψ is the homeomorphism of T^2 which descends from the matrix A .

Remarks. 1. $\text{NIL} \subsetneq \text{Isom}(\text{NIL})$ and $\text{SOL} \subsetneq \text{Isom}(\text{SOL})$.

2. SOL and NIL are different topologically, since NIL has nontrivial center and SOL does not.
3. SOL and NIL are both semi-direct products of $\mathbb{R}^2 \times \mathbb{R}$ (or, non-isomorphic extensions of \mathbb{R}^2 by \mathbb{R}). We can picture NIL as an extension of \mathbb{R}^2 by \mathbb{R} :

$$0 \longrightarrow \mathbb{R} \longrightarrow \text{NIL} \xrightarrow{\phi} \mathbb{R}^2 \longrightarrow 0$$

where the first $\mathbb{R} \cong \left\{ \begin{pmatrix} 1 & 0 & z \\ 0 & 1 & 0 \\ 0 & 0 & 1 \end{pmatrix} \mid z \in \mathbb{R} \right\}$ is central, and ϕ is given by

$$\phi \left(\begin{pmatrix} 1 & x & z \\ 0 & 1 & y \\ 0 & 0 & 1 \end{pmatrix} \right) = (x, y).$$

In this sense, NIL is “just a twisted version of” the more natural extension

$$0 \longrightarrow \mathbb{R} \longrightarrow \mathbb{E}^3 \longrightarrow \mathbb{R}^2 \longrightarrow 0.$$

The final 3-dimensional geometry we consider is a twisted version of $\mathbb{H}^2 \times \mathbb{R}$, denoted $\widetilde{\text{SL}}_2$. This arises from the question of whether there is a twisted version of $\mathbb{H}^2 \times \mathbb{R}$ as NIL is for $\mathbb{E}^2 \times \mathbb{R}$. To define it, first note that $\text{SL}_2(\mathbb{R})$ is a 3-dimensional, connected Lie group. It is not simply connected, as it contains a maximal compact subgroup isomorphic to $\text{SO}(2)$. We therefore pass to the universal cover of $\text{SL}_2(\mathbb{R})$; this is $\widetilde{\text{SL}}_2$. It is a 3-dimensional Lie group, and $\widetilde{\text{SL}}_2$ with its left invariant metric is a geometry. It is possible to construct examples modelled on this, though we do not do so at present.

The following theorem summarizes the 3-dimensional geometries.

Theorem (Thurston). *There are exactly eight 3-dimensional geometries; they are:*

$$\mathbb{S}^3, \mathbb{E}^3, \mathbb{H}^3, \mathbb{S}^2 \times \mathbb{R}, \mathbb{H}^2 \times \mathbb{R}, \text{NIL}, \widetilde{\text{SL}}_2, \text{SOL}.$$

Remark. These fall into four categories:

- $\mathbb{S}^3, \mathbb{E}^3, \mathbb{H}^3$ all have constant curvature;
- $\mathbb{S}^2 \times \mathbb{R}$ and $\mathbb{H}^2 \times \mathbb{R}$ are products;
- NIL and $\widetilde{\text{SL}}_2$ are twisted products;
- SOL is its own thing.

Remark. $\text{Isom}(\text{NIL})$ contains NIL of infinite index, because there is a circle action on NIL by isometries; that is, there exists $C \subset \text{Isom}(\text{NIL})$ such that C acts like S^1 on NIL (cf. Scott’s article). As before, this can be described in terms of (x, y, z) co-ordinates:

$$((x, y), z) \mapsto (\rho_\theta(x, y), f(x, y, z, \theta))$$

where ρ_θ is rotation by $\theta \in [0, 2\pi)$.

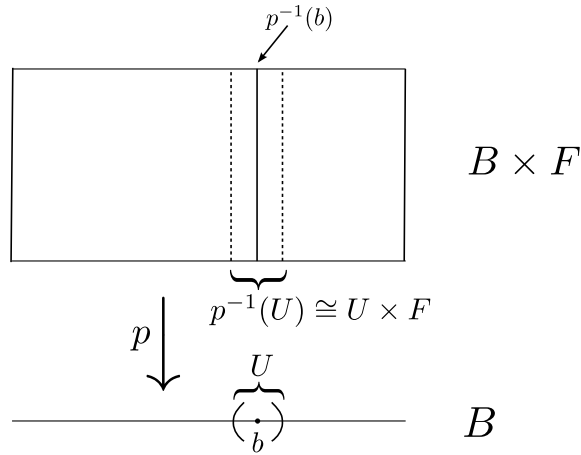

Figure 1.22: Bundle projection $p : E \rightarrow B$

Bundles

Definition. Let E, B be topological spaces and $p : E \rightarrow B$ be a continuous surjection. Then we say that p is a *bundle projection* (see Figure 1.22) if there is a space F such that for each $x \in B$ there is a neighborhood U containing x and a homeomorphism $\varphi_U : U \times F \rightarrow p^{-1}(U)$ such that

$$p \circ \varphi_U : U \times F \rightarrow U$$

is the projection onto the first factor (see Figure 1.23).

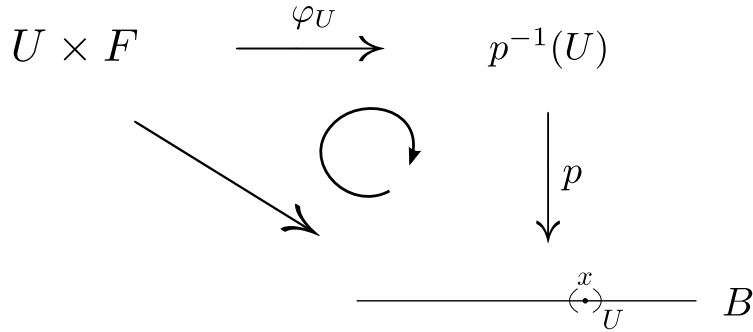

Figure 1.23: The map $p \circ \varphi_U$ is projection onto the first factor

In this situation, we call the data (E, B, F, p) a *fiber bundle* with base B , fiber F , and total space E . We also say that E fibers over B and write

$$F \rightarrow E \xrightarrow{p} B.$$

Example. If $E = B \times F$ with p the projection to the first factor, then this is called the trivial fiber bundle.

Example. Let M be the Möbius band. Then M is a non-trivial fiber bundle with base S^1 and fiber $I = [0, 1]$ (see Figure 1.24).

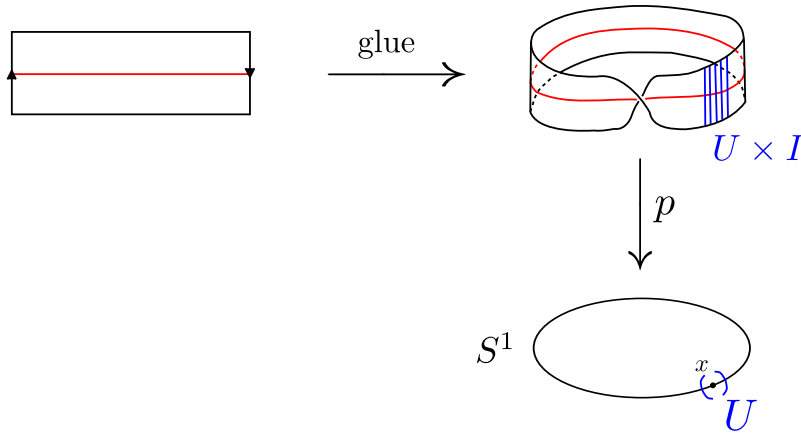

Figure 1.24: The Möbius band is an I -bundle over S^1

When F is a compact surface, we call E a *surface bundle* and when F is homeomorphic to S^1 , we call E a *circle bundle*.

Observe that for 3-manifolds, surfaces bundles have base S^1 and circle bundles have base a surface.

Example. Take Σ to be a compact surface. Then $\Sigma \times S^1$ is both a surface bundle and a circle bundle.

Example. Again, take Σ to be a compact surface and let $\phi : \Sigma \rightarrow \Sigma$ be a homeomorphism. Then the mapping torus

$$M_\phi = \Sigma \times I / (x, 0) \sim (\phi(x), 1)$$

is a surface bundle over S^1 . We call ϕ the monodromy of the bundle.

Definition. Let M be a compact 3-manifold. M is called a Seifert Fibered Space (SFS) if M is virtually a circle bundle, i.e. M is finitely covered by a circle bundle.

Example. By the Bieberbach theorems, if M is a closed manifold modelled on the Euclidean geometry then M is finitely covered by T^3 and hence a SFS.

Example. Recall that NIL is a central extension

$$0 \rightarrow \mathbb{R} \rightarrow \text{NIL} \rightarrow \mathbb{R}^2 \rightarrow 0.$$

As we saw before, NIL/H is a circle bundle over T^2 :

$$0 \rightarrow \mathbb{Z} \rightarrow \text{NIL}/H \rightarrow \mathbb{Z}^2 \rightarrow 0;$$

using the action of the central \mathbb{Z} on \mathbb{R} and the \mathbb{Z}^2 action on \mathbb{R}^2 , this can be shown to give a circle bundle structure on $H \backslash \text{NIL}$.

Example. Let $M = \mathbb{H}^3/\Gamma$ have finite volume. Then M is not a Seifert Fibered Space.

We now return to the proof of Theorem 1.1. In order to prove that all geometric manifolds are residually finite, we make use of the following theorem.

Theorem (Thurston/Perelman). *Let M be an orientable, closed, geometric 3-manifold. Then one of the following holds:*

1. M has geometry modelled on S^3 (i.e. $\pi_1 M$ is finite);

2. M has geometry modelled on \mathbb{H}^3 ;
3. M has geometry modelled on \mathbb{R}^3 and is finitely covered by T^3 ;
4. M has geometry modelled on $S^2 \times \mathbb{R}$ and is finitely covered by $S^2 \times S^1$;
5. M is finitely covered by a circle bundle over Σ_g where $g \geq 1$. In this case, M has geometry modelled on either $\mathbb{H}^2 \times \mathbb{R}$, NIL, or $\widetilde{\text{SL}}_2$;
6. M has geometry modelled on SOL. Here, M is finitely covered by a torus bundle over S^1 with hyperbolic monodromy.

Perelman has proven the following theorem.

Theorem. *If M is a closed, irreducible 3 manifold with infinite fundamental group and $\mathbb{Z} \times \mathbb{Z} \not\subseteq \pi_1 M$, then M is hyperbolic.*

In the same spirit, we have the following theorem.

Theorem (Thurston). *Let M be a compact 3-manifold with non-empty boundary consisting of incompressible tori. Assume that $\text{Int } M$ admits a geometric structure of finite volume, and that $\pi_1 M$ is not virtually abelian. Then M is either modelled on \mathbb{H}^3 or is virtually $P \times S^1$ for a punctured surface P .*

Remark. By the classification theorem above, in order to prove residual finiteness of geometric manifolds we need to understand the fundamental groups of circle bundles. If $E = \Sigma_g \times S^1$ then we have $\pi_1 E = \pi_1 \Sigma_g \times \pi_1 S^1$ and the obvious short exact sequence

$$1 \rightarrow \mathbb{Z} \rightarrow \pi_1 E \rightarrow \pi_1 \Sigma_g \rightarrow 1.$$

More generally, if E is any circle bundle over Σ_g ($g \geq 1$) then we have the short exact sequence

$$1 \rightarrow \mathbb{Z} \rightarrow \pi_1 E \rightarrow \pi_1 \Sigma_g \rightarrow 1.$$

with the presentation

$$\pi_1 E = \langle a_1, b_1, \dots, a_g, b_g, h \mid [a_i, h] = [b_i, h] = 1, \prod_i [a_i, b_i] = h^e \rangle$$

where e is a positive integer.

Example. Taking $g=e=1$, the presentation becomes

$$\langle a, b, h \mid [a, h] = [b, h] = 1, [a, b] = h \rangle.$$

This is the integral Heisenberg groups H seen previously.

Theorem 1.14. *Suppose M is closed, orientable, and geometric. Then $\pi_1 M$ is residually finite.*

Proof. From before, manifolds modelled on $S^3, \mathbb{E}^3, \mathbb{H}^3, S^2 \times \mathbb{R}$, and $\mathbb{H}^2 \times \mathbb{R}$ are residually finite. So by the classification theorem above, it suffices to deal with the cases when (1) M is a circle bundle or (2) M is modelled on SOL.

For (1), first suppose $g = 1$. Then

$$\pi_1 M = \langle a, b, h \mid [a, h] = [b, h] = 1, [a, b] = h^e \rangle$$

and we see that M is a finite cover of NIL/H . Hence, $\pi_1 M$ is RF since H is linear. For $g \geq 2$, set

$$\Gamma = \pi_1 M = \langle a_1, b_1, \dots, a_g, b_g, h \mid [a_i, h] = [b_i, h] = 1, \prod_i [a_i, b_i] = h^e \rangle$$

and observe that $\Gamma/\langle h \rangle = \pi_1 \Sigma_g$. If $g \in \Gamma$ but $g \notin \langle h \rangle$ then g projects non-trivially into $\pi_1 \Sigma_g$ so, since surface groups are RF, we can find a finite quotient of $\pi_1 \Sigma_g$, and hence Γ , not mapping g to the identity. To deal with $\langle h \rangle$, we construct a homomorphism $\varphi : \Gamma \rightarrow \text{NIL}$ with $\varphi(h) \neq 1$. Define φ by first setting

$$\varphi(a_1) = \begin{pmatrix} 1 & x & 0 \\ 0 & 1 & y \\ 0 & 0 & 1 \end{pmatrix}, \quad \varphi(b_1) = \begin{pmatrix} 1 & r & 0 \\ 0 & 1 & s \\ 0 & 0 & 1 \end{pmatrix}, \quad \varphi(a_i) = \varphi(b_i) = 1 \text{ for } i \geq 2.$$

Then we see that

$$\varphi([a_1, b_1]) = \begin{pmatrix} 1 & 0 & sx - ry \\ 0 & 1 & 0 \\ 0 & 0 & 1 \end{pmatrix},$$

so choosing r, s, x, y so that $T = sx - ry \neq 0$, φ can be defined by mapping h to the matrix

$$\begin{pmatrix} 1 & 0 & \frac{T}{e} \\ 0 & 1 & 0 \\ 0 & 0 & 1 \end{pmatrix}.$$

We have therefore constructed a well defined homomorphism $\varphi : \Gamma \rightarrow \text{NIL}$ with $\varphi(h) \neq 1$. Since $\varphi(\Gamma)$ is a finitely generated linear group, it is residually finite. This completes the proof when M is a circle bundle.

For (2), when M is a 3-manifold modelled on the SOL geometry, it suffices to consider a finite cover M_A that is a torus bundle over S^1 with hyperbolic monodromy $A \in \text{SL}_2(\mathbb{Z})$. We have the split exact sequence

$$1 \rightarrow F \rightarrow \pi_1 M_A \rightarrow \mathbb{Z} \rightarrow 1,$$

where $F \cong \mathbb{Z} \times \mathbb{Z}$ is the fundamental group of the fiber torus. To prove residual finiteness, let $g \in \pi_1 M_A$. If $g \notin F$ then g projects nontrivially into \mathbb{Z} and can therefore be mapped non-trivially into a finite quotient. So we assume $g \in F \cong \mathbb{Z} \times \mathbb{Z}$ and let $n \in \mathbb{Z}$ so that

$$g \notin H_n = \text{Ker}(\mathbb{Z} \times \mathbb{Z} \rightarrow \mathbb{Z}/n\mathbb{Z} \times \mathbb{Z}/n\mathbb{Z}).$$

Since H_n is characteristic in F , it is normal in $\pi_1 M_A$. Let $G = H_n.\langle t \rangle$, where t projects to the generator of $\pi_1 S^1 \cong \mathbb{Z}$ in the above sequence. One then easily verifies that G is the required finite index subgroup of $\pi_1 M_A$ that does not contain g , completing the proof. \square

Remark. We can also show that $\text{Isom}(\text{SOL})$ is linear. To see this, first observe that it is enough to show that SOL is linear, as $[\text{Isom}(\text{SOL}) : \text{SOL}] = 8$. Since SOL was described as \mathbb{R}^3 with the multiplication

$$(a, b, c) * (x, y, z) = (a + e^{-c}x, b + e^c y, c + z)$$

we can associate to each (a, b, c) the affine transformation

$$\psi_{(a,b,c)}(x, y, z) = (a, b, c) + (e^{-c}x, e^c y, z).$$

This provides an injective homomorphism from SOL to $\text{Aff}(\mathbb{R}^3)$, which embeds into $\text{GL}_4(\mathbb{R})$ via the map

$$A\underline{x} + b \mapsto \begin{pmatrix} A & b \\ 0 & 1 \end{pmatrix}.$$

We now return to the proof of Theorem 1.1. By Theorem 1.14, any closed manifold admitting a geometric structure is residually finite so by the geometrization theorem (version 1) there is a system of incompressible tori \mathcal{T} such that each component of $M|\mathcal{T}$ is either hyperbolic, a Seifert fibered space, or has virtually abelian fundamental group. Note that all of the components of the torus decomposition are residually finite by previous work.

It remains to show that we can piece together these components to recover the manifold M while preserving residual finiteness. We begin with a warm up that highlights the ideas of the proof.

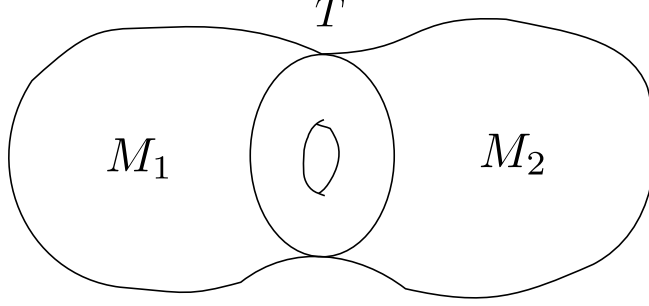

Figure 1.25: M contains an incompressible torus T

Example: Warm Up. Let M be a closed 3-manifold that contains a single incompressible torus T such that $M|_{\mathcal{T}} = M_1 \cup_T M_2$ with M_1, M_2 hyperbolic of finite volume (see Figure 1.25). Set $\pi_1 T = P$ so that we have the non-trivial splitting

$$\pi_1 M = \pi_1 M_1 *_{P} \pi_1 M_2.$$

Let $g \in \pi_1 M \setminus 1$ and suppose that we can find homomorphisms

$$\theta_1 : \pi_1 M_1 \rightarrow A_1,$$

$$\theta_2 : \pi_1 M_2 \rightarrow A_2$$

with A_1, A_2 finite groups so that

$$\theta_1|_P = \theta_2|_P$$

(that is, for each $\alpha \in P$, we have $\theta_1(\alpha) = \theta_2(\alpha)$). Then we set $\bar{P} = \theta_1(P) = \theta_2(P)$ and have the induced homomorphism

$$\bar{\theta} : \pi_1 M \rightarrow A_1 *_{\bar{P}} A_2.$$

Now, if we could arrange the homomorphism so that $\bar{\theta}(g) \neq 1$, then we can find a finite index subgroup of $\pi_1 M$ not containing g , therefore proving residual finiteness. To see this, observe that since finite amalgamations of finite groups are virtually free, and hence residually finite, we can find a map ψ from $A_1 *_{\bar{P}} A_2$ to a finite group that does not map $\bar{\theta}(g)$ to the identity. $\text{Ker } \psi \circ \bar{\theta}$ then provides the required finite index subgroup of $\pi_1 M$ not containing g .

[See Window for proof that finite amalgamations of finite groups are virtually free]

To arrange this situation, we make use of the following two lemmas.

Lemma 1.15. *Let M be an orientable, hyperbolic 3-manifold of finite volume with a single cusp. Let T be the peripheral torus. If $g \in \pi_1 M \setminus \{1\}$, then for all but finitely many primes p there is a normal subgroup N of finite index in $\pi_1 M$ such that*

$$N \cap \pi_1 T = H_p$$

where H_p is the characteristic subgroup of $\pi_1 M$ of index p^2 . Moreover, if $g \notin \pi_1 T$ then $g \notin N \cdot \pi_1 T$.

Proof. Let $\Gamma = \pi_1 M$ and $P \subset \Gamma$ be $\pi_1 T$. Conjugate Γ in $\text{PSL}_2(\mathbb{C})$ so that P fixes ∞ , i.e.

$$P \subset \left\{ \begin{pmatrix} 1 & z \\ 0 & 1 \end{pmatrix} \mid z \in \mathbb{C} \right\}.$$

Now let $g \in \Gamma \setminus P$ (the proof for $g \in P$ is similar), and suppose

$$g = \begin{pmatrix} a & b \\ c & d \end{pmatrix}.$$

Observe that $c \neq 0$, since otherwise either g is parabolic and thus contained in P , or g is a hyperbolic element of Γ sharing a fixed point with P , both of which provide contradictions. Choose a basis for $P = \langle \mu, \lambda \rangle$, where λ is contained the kernel of the map

$$H_1(T, \mathbb{Z}) \rightarrow H_1(M, \mathbb{Z}).$$

[Window: More on half lives half dies]

Let $R \subset \mathbb{C}$ be the ring generated over \mathbb{Z} by the entries of the generators of Γ and their inverses. We state the following lemma without proof.

Lemma 1.16. *Let $R \subset \mathbb{C}$ be a finitely generated ring. Let a_1, \dots, a_n be nonzero elements of R . Then for all but finitely many primes p there exist ring homomorphisms $\psi_p : R \rightarrow \mathbb{F}_{p^n}$ with $\psi_p(a_i) \neq 0$ for $i = 1, \dots, n$.*

[For proof, see Window]

From this above lemma, there exist infinitely many primes p and homomorphisms $\psi_p : R \rightarrow \mathbb{F}_{p^n}$ with

$$\psi_p(m), \psi_p(l), \psi_p(c) \neq 0$$

where m and l are the $(1, 2)$ entries of the matrices μ and λ respectively. For a fixed prime p , this map then defines

$$\bar{\rho} : \Gamma \rightarrow \mathrm{SL}_2(\mathbb{F}_{p^n})$$

with $\bar{\rho}(m)$ and $\bar{\rho}(l)$ elements of order p and $\bar{\rho}(g) \notin \bar{\rho}(P)$. This construction would prove the lemma if we could ensure that

$$\bar{\rho}(P) \cong \mathbb{Z}/p\mathbb{Z} \times \mathbb{Z}/p\mathbb{Z}.$$

However, it is possible that $\bar{\rho}(P) \cong \mathbb{Z}/p\mathbb{Z}$. To avoid this concern, consider the quotient homomorphism

$$\Gamma \rightarrow \Gamma^{\mathrm{ab}}/\mathrm{torsion} = H.$$

Now let

$$\bar{\theta} : \Gamma \rightarrow H/H^p \cong (\mathbb{Z}/p\mathbb{Z})^r$$

with $\bar{\theta}(P) \cong \mathbb{Z}/p\mathbb{Z}$ by construction. Taking

$$N = \mathrm{Ker}(\bar{\rho} \times \bar{\theta} : \Gamma \rightarrow \mathrm{SL}_2(\mathbb{F}) \times H/H^p)$$

is then the required normal subgroup. □

We can now finish the proof that $\pi_1 M$ is residually finite for M as in our warm up example. Let $g \in \pi_1 M \setminus \{1\}$. Then we write g in the reduced form

$$g = g_1 h_1 \dots g_n h_n$$

where $g_i \in \pi_1 M_1$, $h_i \in \pi_1 M_2$, and $g_i, h_i \notin P$ for $i > 1$ (and, as we saw above, there are variations on where this word begins and ends). If $g \in P$, then for all but finitely many primes p , we have $g \notin H_p$. Hence the first part of Lemma 1.15 provides finite index subgroups $N_1 \triangleleft \pi_1 M_1$ and $N_2 \triangleleft \pi_1 M_2$ with

$$N_1 \cap P = N_2 \cap P = H_p.$$

We then have $\bar{\theta}(g) \neq 1$ as required.

If instead $g \notin P$, then write g in reduced form as above. By Lemma 1.15, there are finite index subgroups $N_1 \triangleleft \pi_1 M_1$ and $N_2 \triangleleft \pi_1 M_2$ with

$$\theta_1 : \pi_1 M_1 \rightarrow A_1 = \pi_1 M_1 / N_1$$

$$\theta_2 : \pi_1 M_2 \rightarrow A_2 = \pi_1 M_2 / N_2$$

so that $\theta_1(g_i) \notin \theta_1(P)$, $\theta_2(h_j) \notin \theta_2(P)$, and

$$N_1 \cap P = H_p = N_2 \cap P.$$

We now obtain the desired homomorphism

$$\bar{\theta} : \pi_1 M \rightarrow A_1 *_{\bar{P}} A_2$$

with $\bar{\theta}(g) \neq 1$ by the final part of Lemma 1.15.

Remark. The key lemma, 1.15, holds for an arbitrary finite volume hyperbolic manifold with cusps.

Proof. Let $\Gamma = \pi_1 M$, where M has cusp tori T_1, \dots, T_n with groups P_1, \dots, P_n . Conjugate Γ such that

$$P_1 = \left\langle \left(\begin{pmatrix} 1 & m_1 \\ 0 & 1 \end{pmatrix}, \begin{pmatrix} 1 & l_1 \\ 0 & 1 \end{pmatrix} \right) \right\rangle = \langle \mu_1, \lambda_1 \rangle.$$

Now there exist $A_2, \dots, A_n \in \mathrm{SL}_2(\mathbb{C})$ such that for each $j = 2, \dots, n$,

$$A_j P_j A_j^{-1} = \left\langle \left(\begin{pmatrix} 1 & m_j \\ 0 & 1 \end{pmatrix}, \begin{pmatrix} 1 & l_j \\ 0 & 1 \end{pmatrix} \right) \right\rangle = \langle \mu_j, \lambda_j \rangle,$$

where λ_j was constructed to be killed by the inclusion map of the boundary. Let R be the ring generated over \mathbb{Z} by the entries of generators of Γ and the entries of A_j, A_j^{-1} . The first part proceeds as before: let

$$g = \begin{pmatrix} a & b \\ c & d \end{pmatrix},$$

with $c \neq 0$. Take primes from Lemma 1.16 so that $\psi_p(c), \psi_p(m_j), \psi_p(l_j) \neq 0$. Now we must arrange the following: fix $P \in \{P_1, \dots, P_n\}$. If $g \in \pi_1 M \setminus P$, then $g \notin N \cdot P$. Repeat argument as needed. \square

We need to develop some group theory to handle the general case where the set of incompressible tori \mathcal{T} is non-empty. If we cut M along \mathcal{T} (see Figures 1.26 and 1.27) then each piece is RF, by the above work.

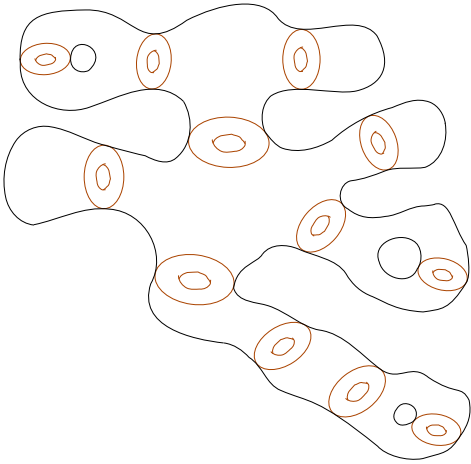

Figure 1.26: M and \mathcal{T}

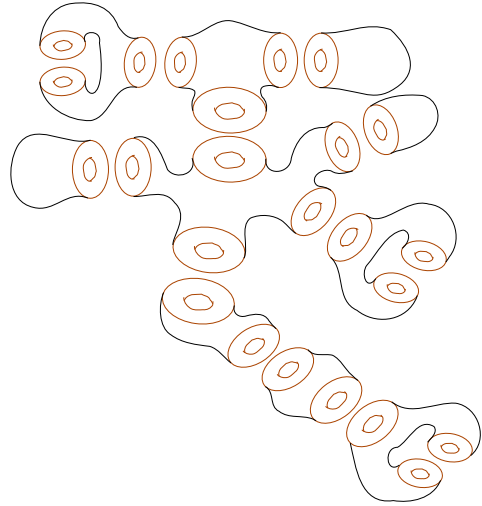

Figure 1.27: M cut along \mathcal{T}

In order to show that the fundamental group of such an M is RF, we need to use the *fundamental group of a graph of groups* (Serre, Bass, Dicks–Dunwoody).

Gluing two tori of different components together is a free product amalgamation. Gluing two tori together of the same component is an HNN-extension. More precisely, let $G = \pi_1 N$, T and T' two distinct boundary components of the same piece. If $P, Q \subset G$, peripheral subgroups associated to T, T' , then after gluing T to T' , we get:

$$G^* = \langle G, t \mid tpt^{-1} = \phi_*(p) \ \forall p \in P \rangle,$$

where $\phi_* : P \rightarrow Q$ is an isomorphism.

Definition. A *graph* Y consists of two sets: $V = V(Y)$, vertices, and $E = E(Y)$, (oriented) edges, together with maps $E \rightarrow V \times V$, $e \mapsto (o(e), t(e))$ (the originating and terminating vertices of e), and $E \rightarrow E$, $e \mapsto \bar{e}$ (reversal of orientation) such that $\bar{\bar{e}} = e$, $\bar{e} \neq e$, $t(e) = o(\bar{e})$, and $o(e) = t(\bar{e})$.

We usually think in terms of diagrams, for example

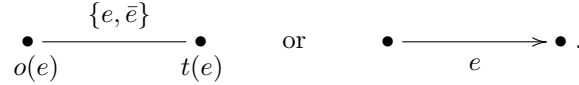

All graphs will be assumed to be connected, oriented, and finite.

Definition. A *graph of groups*, \mathcal{G} , based on a graph Y , consists of two families of groups $\{G_v \mid v \in V\}$ and $\{G_e : e \in E\}$ such that $G_e = G_{\bar{e}}$, and a family of group embeddings $\{f_e\}$ with $f_e : G_e \hookrightarrow G_{t(e)}$, $f_{\bar{e}} : G_{\bar{e}} \hookrightarrow G_{o(e)}$.

Example. Let Y be the graph

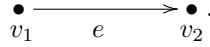

Then there is one edge group $G_e = G_{\bar{e}}$ and we have two embeddings from G_e into G_{v_1} and G_{v_2} :

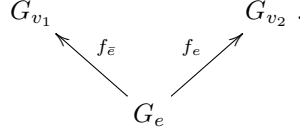

Example. Let Y be the graph with one vertex and one edge.



Here we have two embeddings of the only edge group $G_e = G_{\bar{e}}$ into the only vertex group G_v .

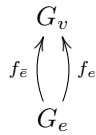

Definition. The *Path Group*, $\pi(\mathcal{G})$, is:

$$\pi(\mathcal{G}) := \left(\underset{v \in V}{*} G_v \right) * F(E) / N$$

where $F(E)$ is a free group with basis the elements of E , and N is the normal subgroup generated by the relations $ef_e(g)e^{-1} = f_{\bar{e}}(g)$ for all $e \in E$ and $g \in G_e$, and $e^{-1} = \bar{e}$ for all $e \in E$.

Example. Take $G_v = 1 \forall v \in V$. Then, since the maps f_e are embeddings, we must have $G_e = 1 \forall e \in E$. Then $\pi(\mathcal{G}) = F$, the free group on $\frac{|E|}{2}$ generators.

Example. Suppose $G_e = 1 \forall e \in E$. Then $\pi(\mathcal{G}) = \left(\ast_v G_v \right) \ast F$, where again F is free on $\frac{|E|}{2}$ generators.

To explain the use of the name “Path Group”, consider the following definition. A *path* γ in \mathcal{G} of length n from a vertex v to a vertex w is a sequence $(g_0, e_1, g_1, \dots, e_n, g_n)$, where (e_1, \dots, e_n) is an edge path in Y and $g_i \in G_{v_i}$ for $i = 0, 1, \dots, n$, where $v_i = t(e_i)$, $i = 1, 2, \dots, n$.

Remark. A path γ determines a word $\gamma = g_0 e_1 g_1 \dots e_n g_n$ in $\pi(\mathcal{G})$. We multiply paths by concatenation so long as terminal vertex and original vertex the paths agree.

Example. Consider the following path in \mathcal{G} : $\gamma = (g_0, e_1, g_1, e_2, g_2)$ with $e_2 = \bar{e}_1$. This determines $\gamma = g_0 e_1 g_1 \bar{e}_1 g_2 = g_0 e_1 g_1 e_1^{-1} g_2 \in \pi(\mathcal{G})$. Now suppose $g_1 \in f_{e_1}(G_{e_1})$, i.e. $g_1 = f_{e_1}(h)$ for some $h \in G_{e_1}$. Then $\gamma = g_0 e_1 f_{e_1}(h) e_1^{-1} g_2 = g_0 f_{\bar{e}_1}(h) g_2$. Here $g_0 \in G_{v_0}$, $g_2 \in G_{v_2} = G_{o(e_1)} = G_{v_0}$, $f_{\bar{e}_1}(h) \in G_{v_0}$. Therefore the path of length 2 collapses to a path of length zero.

Definition. A path γ is a *reduced path* if $n = 0$ and $g_0 \neq 1$, or if $n > 0$ and $g_i \notin f_{e_i}(G_{e_i})$ for each i such that $e_{i+1} = \bar{e}_i$.

Remark: Key Properties (Serre).

- If $g \in \pi(\mathcal{G})$, $g \neq 1$, then g can be represented by a reduced path.
- If γ is a reduced path, then γ determines a non-trivial word in $\pi(\mathcal{G})$.
- $G_v \hookrightarrow \pi(\mathcal{G})$ is injective.

[See Window for proofs]

Next we have two definitions of the *fundamental group of a graph of groups*.

Definition. Let $v_0 \in V$ be fixed. Then $\pi_1(\mathcal{G}, v_0)$ is the subgroup of $\pi(\mathcal{G})$ where paths begin and end at v_0 .

Definition. Let $T \subset Y$ be a maximal tree. Note that T is connected, and meets every vertex. Define $\pi_1(\mathcal{G}, T) = \pi(\mathcal{G}) / \langle e = 1 \forall t \in E(T) \rangle$.

Exercise. (see Serre.) $\pi(\mathcal{G}) \twoheadrightarrow \pi_1(\mathcal{G}, T)$ surjects. This homomorphism, when restricted to $\pi_1(\mathcal{G}, v_0)$ gives an isomorphism.

Now we have the tools to complete the proof of Theorem 1.1. At this point, M is closed, orientable, irreducible, and the collection of tori $\mathcal{T} \neq \emptyset$.

Let $\Gamma = \pi_1 M$. Suppose that $M \setminus \mathcal{T}$ has pieces $\{N_j\}$, where each N_j is either hyperbolic or a Seifert fibered space (see Figure 1.28). Let $\{T_k\}$ be the boundary tori. Associate to M a graph $Y = Y_M$, where vertices $V(Y)$ correspond to the pieces $\{N_j\}$, and edges $E(Y)$ correspond to the edges between N_j and N_k if ∂N_j and ∂N_k have a common boundary torus (and a loop based at N_j if two distinct boundary tori are identified). Thus we have a bijection between the tori of \mathcal{T} and the edges of Y . This associates to M a graph of groups \mathcal{G} with vertices $\{G_v = \pi_1 N_j\}$ and edges $\{G_e = \pi_1 T_i\}$, together with $G_e = G_{\bar{e}}$ and the maps $f_e, f_{\bar{e}}$ as before.

Exercise. Show that Van Kampen’s Theorem implies that $\Gamma \cong \pi_1(\mathcal{G})$.

We want to show Γ is residually finite. We have already shown all the G_v are residually finite. Now we use the following lemma:

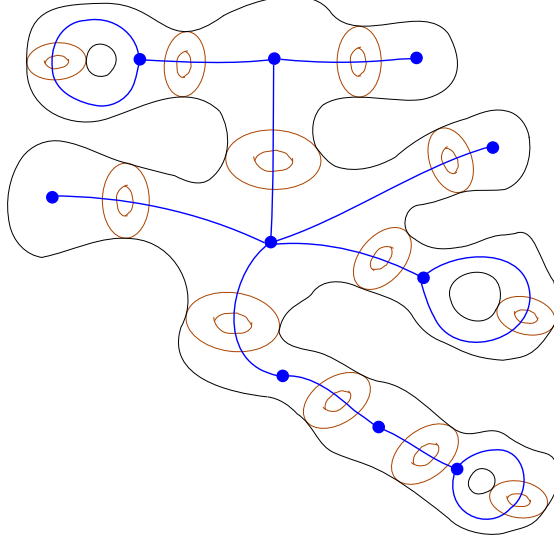

Figure 1.28: The graph Y_M associated to M

Lemma 1.17. *Let M be a compact, orientable 3-manifold which is either a Seifert fibered space or such that $\text{Int } M$ is hyperbolic of finite volume. Let T_1, \dots, T_m be the torus boundary components of M . If $g \in \pi_1 M \setminus \{1\}$, then for all but finitely many primes p , there exists a finite index normal subgroup $N \triangleleft \pi_1 M$ such that $N \cap \pi_1 T_i = H_p$, where H_p is the characteristic subgroup defined above. If $T \in \{T_1, \dots, T_n\}$ and $g \in \pi_1 M \setminus \pi_1 T$, then $g \notin N \cdot \pi_1 T$.*

Proof. We have already done the case when $\text{Int } M$ is hyperbolic. Consider the case when $M = P \times S^1$, where P is a punctured surface. So $\pi_1 M = \pi_1 P \times \mathbb{Z}$. Let $\langle h \rangle$ generate \mathbb{Z} , and φ be the projection

$$\varphi : \pi_1 M / \langle h \rangle \rightarrow \pi_1 P.$$

Each boundary component of M has the form $\{\text{puncture}\} \times S^1$. Fix attention on one such $T \subset \partial M$. Then $\pi_1(T) = \langle \alpha, h \rangle \subset \pi_1 M$ (see Figure 1.29). Suppose that $g \in \pi_1 M \setminus \pi_1 T$. Then $\varphi(g) = g' \in \pi_1 P \setminus \langle \alpha \rangle$.

To prove the lemma, it suffices to show there exists a finite index normal subgroup $N \triangleleft \pi_1 P$ such that $N \cap \langle \alpha \rangle$ has index p in $\langle \alpha \rangle$, and $g' \notin N \cdot \langle \alpha \rangle$. Viewing $\pi_1 P$ as a subgroup of $\text{SL}_2(\mathbb{R})$, we run through the same argument as in the hyperbolic case. \square

We now use this lemma to complete the proof of Theorem 1.1. Let $g \in \Gamma \setminus \{1\}$. Use Lemma 1.17 to define a homomorphism $\bar{\theta} : \Gamma \rightarrow \pi_1(\mathcal{G})$, where all the vertex groups and edge groups are finite.

Remark: Key Fact. Such a $\pi_1(\mathcal{G})$ is virtually free (Stallings, Swan, Serre). Therefore $\pi_1(\mathcal{G})$ is residually finite, so if $\bar{\theta}(g) \neq 1$, then Γ is residually finite, and we are done. To achieve this goal, represent g by a reduced path (using $\Gamma \cong \pi_1(\mathcal{G})$), $g = (g_0, e_1, g_1, \dots, e_n, g_n)$, $g_i \in G_{v_i} \cong \pi_1(N_i)$. Using Lemma 1.17, for each g_i there exists $\theta_i : G_{v_i} \rightarrow G_{v_i}/D_i$, where D_i is the normal subgroup given by the lemma. Furthermore, the θ_i 's agree on any common edge group. This determines a new graph of groups $\bar{\mathcal{G}}$ (where everything is finite). Hence, by construction we can define $\bar{\theta} : \Gamma \rightarrow \pi_1 \bar{\mathcal{G}}$, where $\bar{\theta}(g) = (\theta_0(g_0), e_1, \theta_1(g_1), \dots, e_n, \theta_n(g_n))$.

By the remark above, to show that $\bar{\theta}(g) \neq 1$ it suffices to show:

Claim. $\bar{\theta}(g)$ is reduced.

Proof. If $n = 0$, $g = g_0$. Lemma 1.17 shows that $\bar{\theta}(g) = \theta_0(g_0) \neq 1$. If $n > 0$, then there exists an i such that $\theta_i(g_i) \in \theta(G_{e_i})$, that is, $g_i \in D_i \cdot G_{e_i}$, a contradiction to Lemma 1.17. This completes the proof of Theorem 1.1. \square

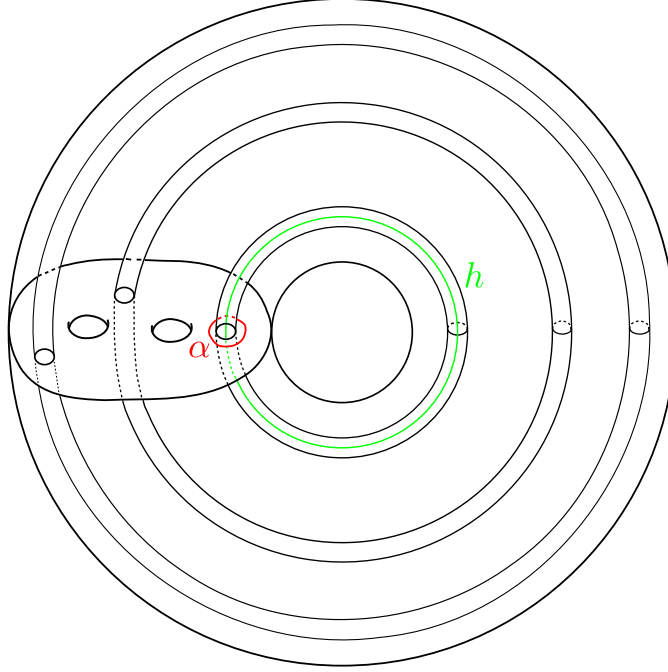

Figure 1.29: $M = P \times S^1$. Here $\pi_1 T = \langle \alpha, h \rangle \subset \pi_1 M$

Remarks. Let M be a closed, orientable irreducible 3-manifold with infinite π_1 . Assume that either M is geometric, but not modelled on \mathbb{H}^3 , or that \mathcal{T} is nonempty. Then there exists a finite cover $M_1 \rightarrow M$ with first betti number $b_1(M_1) > 0$.

Proof. If M is geometric, then M is modelled on \mathbb{E}^3 , NIL, $\widetilde{\text{SL}}_2$, $\mathbb{H}^2 \times \mathbb{R}$, or SOL. Of these, \mathbb{E}^3 is covered by the 3-torus T^3 ; NIL is covered by a T^2 -bundle; $\mathbb{H}^2 \times \mathbb{R}$ and SOL are covered by S^1 -bundles over a closed genus g surface Σ_g , $g \geq 2$; and SOL is virtually a T^2 -bundle. In each case, the listed finite cover M_1 has $b_1(M_1) > 0$. If \mathcal{T} is nonempty, then the proof of Theorem 1.1 gives a surjection $\pi_1 M \twoheadrightarrow G$, where G is virtually free, so $b_1(M_1) > 0$. \square

Furthermore, for $\widetilde{\text{SL}}_2$, $\mathbb{H}^2 \times \mathbb{R}$, we have finite covers with $\pi_1 M_1 \twoheadrightarrow F_2$. This is also true when $\mathcal{T} \neq \emptyset$. We can arrange that $\pi M \twoheadrightarrow F_2$ using graphs $\bar{\mathcal{G}}$ from the proof of Theorem 1.1 (this is Luecke's Thesis).

2 Topology of Finite Sheeted Covers

The standing assumption for this section will be to let M be a closed, connected, orientable, irreducible 3-manifold. Such a manifold M is called *Haken* if M contains an incompressible surface. By the assumption that M is irreducible, it is assumed that such an incompressible surface has positive genus.

Haken manifolds come in two different flavors: vanilla and Belgian raspberry chocolate truffle. The former consists of the cases when the incompressible surface Σ is separating, and the latter of the cases when Σ is non-separating. When Σ is non-separating, then $b_1(M) > 0$. This is an exercise in Poincaré duality. The surface Σ represents a nontrivial class in $H_2(M; \mathbb{Z})$, so there exists a nontrivial class in $H_1(M; \mathbb{Z})$, which is found by considering a 1-cycle in M which intersects Σ only once. By Poincaré duality

$$H_2(M; \mathbb{Z}) = H^1(M; \mathbb{Z}) = \text{Hom}(H_1(M; \mathbb{Z}), \mathbb{Z}).$$

In summary:

Lemma 2.1. *For any n -manifold M and any submanifold $\Sigma \subset M$ of codimension 1, the class $[\Sigma] \in H_{n-1}(M)$ is trivial if and only if Σ separates M .*

In dimension three, the converse to the above lemma also holds.

Proposition 2.2. *Let M^3 be as above (closed, connected, orientable, and irreducible) and assume $b_1(M) > 0$. Then M contains an incompressible non-separating surface.*

Proof. Let $\varphi : \pi_1 M \rightarrow H_1(M; \mathbb{Z}) \twoheadrightarrow \mathbb{Z}$ be an epimorphism. Then we can realize φ as follows (using the asphericity of M): there exists a continuous map $f : M \rightarrow S^1$ with $f_* = \varphi$. Let x_0 be a generic regular value of f such that $f^{-1}(x_0) = F$ is an embedded orientable (possibly disconnected) surface in M . Since φ is onto, there exists a simple closed curve $\gamma \subset M$ such that $\varphi([\gamma]) = z$, where z is a generator of $\pi_1(S^1)$. Then by construction, the intersection number $[\gamma] \cdot [F] = 1$, so $[\gamma] \cdot [F_0] = 1$ for some component $F_0 \subset F$.

If F_0 is incompressible, then we are done. If it is compressible, then, using the Loop Theorem, we can compress it along some embedded disk $D \subset M$ with $D \cap F_0 = \partial D$ to form F'_0 . Then, for some component $F_1 \subset F_0$ we still have $[\gamma] \cdot [F_1] = 1$.

Again, if F_1 is incompressible, we are done. If it is not, then we can repeat this process, eventually arriving at some F_k which is incompressible and non-separating with $[\gamma] \cdot [F_k] = 1$. \square

Definition. For any 3-manifold M as above, the *virtual first Betti number* of M is given by

$$vb_1(M) = \sup\{b_1(X) : X \rightarrow M \text{ is a finite sheeted covering of } M\}.$$

A group G is called *large* if it contains a subgroup H of finite index which surjects onto a free group.

With the above two terms in hand, we can now state what may be considered to be the biggest open problem in 3-manifold topology.

Conjecture. (Main Open Problems in 3-manifold topology)

Let M be as above, and assume $\pi_1 M$ is infinite. Then,

- (A) M is virtually Haken;
- (B) $vb_1(M) > 0$;
- (C) $vb_1(M) = \infty$;
- (D) $\pi_1 M$ is large.

Remarks. 1. By the work above, Conjecture (B) implies Conjecture (A). In fact,

$$(D) \implies (C) \implies (B) \implies (A).$$

2. If M is modelled on \mathbb{E}^3 , then $vb_1(M) = 3$, since M is finitely covered by T^3 .
3. If M is modelled on NIL, then $vb_1(M) = 2$. If M is modelled on $S^2 \times \mathbb{R}$, or on SOL, then $vb_1(M) = 1$.
4. If M is modelled on $\mathbb{H}^2 \times \mathbb{R}$, or on $\widetilde{\text{SL}}_2$, then $\pi_1 M$ is large, since M is virtually a circle bundle over a surface of genus $g \geq 2$.
5. If M is hyperbolic, then the conjectures are open in general.

Theorem 2.3. *Let M be as above, with $|\pi_1 M| = \infty$. Assume that M is not hyperbolic. Then $vb_1(M) > 0$, and either*

- (i) M is modeled on \mathbb{E}^3 , SOL, NIL, or $S^2 \times \mathbb{R}$ and $vb_1(M) \leq 3$; or
- (ii) $\pi_1 M$ is large.

Proof. By geometrization, if M is not hyperbolic, then either M is geometric and we are done by the remarks above, or (recalling the notation used in the proof of Theorem 1.1) M contains a nonempty collection \mathcal{T} of irreducible tori. In that proof, we constructed (many) epimorphisms $\varphi : \pi_1 M \rightarrow \pi_1(\overline{\mathcal{G}})$, where $\overline{\mathcal{G}}$ is a graph of groups with all the vertex groups finite. As we saw in the proof (***) or in a window***), $\pi_1(\overline{\mathcal{G}})$ is virtually free, so $vb_1(M) > 0$.

However, we have a problem if $\pi_1(\overline{\mathcal{G}})$ is virtually \mathbb{Z} . Recall that the vertex groups had the form $\text{PSL}_2(\mathbb{F}_p) \times (H/H^p)$, where H was the free part of $(\pi_1 M)^{\text{ab}}$. In the proof, the edge groups always had the form $\mathbb{Z}/p\mathbb{Z} \times \mathbb{Z}/p\mathbb{Z}$. The image of a peripheral subgroup of the fundamental group of a piece of $M \setminus \mathcal{T}$ in $\text{PSL}_2(\mathbb{Z})$ is $\mathbb{Z}/p\mathbb{Z}$, and the index of this subgroup is much bigger than 2. Also, the image of the edge groups in the vertex groups was larger than 2.

With this in mind, one way to finish the proof is to apply the following theorem. □

Theorem (Serre, Stallings). *$\pi_1(\overline{\mathcal{G}})$ is virtually \mathbb{Z} if and only if either $\pi_1(\overline{\mathcal{G}})$ contains a finite normal subgroup N such that $\pi_1(\overline{\mathcal{G}})/N \cong \mathbb{Z}$ or $\pi_1(\overline{\mathcal{G}}) \cong A *_C B$, where $[A : C] = [B : C] = 2$.*

Separability

Let G be a group. Given a subgroup $H < G$, G is called *H-separable* if for all $g \in G \setminus H$ there exists a homomorphism $\varphi : G \rightarrow A$, where A is a finite group and $\varphi(g) \notin \varphi(H)$. A group G is called *subgroup separable* or LERF (*locally extended residually finite*) if G is H -separable for all finitely generated $H < G$. If H is taken to be the trivial subgroup, this definition matches that of RF. The “locally extended” refers only to finitely generated subgroups, as infinitely generated subgroups need not in general be separable.

In parallel with the reformulations equivalent to residual finiteness, we see that the condition of H -separability is equivalent to the following two conditions:

- (i) for all $g \in G \setminus H$, there exists a finite index subgroup $K < G$ such that $H < K$ and $g \notin K$; and
- (ii) $\bigcap_{H < K < G} K = H$, where $[G : K] < \infty$.

Theorem 2.4. *Let M be a compact 3-manifold, and let $A < \pi_1 M$ be a maximal abelian subgroup. Then $\pi_1 M$ is A -separable.*

Proof. Let $\Gamma = \pi_1 M$. Then, by Theorem 1.1, Γ is residually finite. Let $\{N_i\}$ be a family of finite index normal subgroups in Γ with $\bigcap N_i = 1$.

Claim. $\bigcap AN_i = A$.

This claim proves the theorem since $\bigcap_{A < K < G} K \subset \bigcap AN_i = A$, where $K < G$ is finite index. To prove the claim, let $g \in \bigcap AN_i$ and let $a \in A$. Consider $gag^{-1}a^{-1}$. Since $g \in AN_i$ for all i , $g = xn_i$ with $x \in A$ and $n_i \in N_i$. So

$$gag^{-1}a^{-1} = (xn_i)a(xn_i)^{-1}a^{-1} = xn_i a n_i^{-1} x^{-1} a^{-1} = xn_i n_i' x^{-1},$$

since A is abelian and N_i is normal. It follows that $gag^{-1}a^{-1} \in N_i$ for all i , which implies that $gag^{-1}a^{-1} = 1$. Thus, g and a commute, and $\langle g, A \rangle$ is abelian. Since A was maximal abelian, $g \in A$, so $\bigcap AN_i = A$. \square

A particular case of the above theorem occurs when $A < \pi_1 M$ is the fundamental group of a peripheral torus, i.e., $T^2 \subset \partial M$. The following proposition says that $\pi_1 M$ is *peripherally separable*.

Proposition 2.5. *Let M be a compact 3-manifold, and $\Sigma \subset \partial M$ some incompressible surface of genus $g \geq 1$. Let $\Gamma = \pi_1 M$ and $H = \pi_1 \Sigma$. Then Γ is H -separable.*

This follows from Theorem 1.1 and the next lemma, since the double of M over Σ , which has $G *_H G$ as its fundamental group, is residually finite.

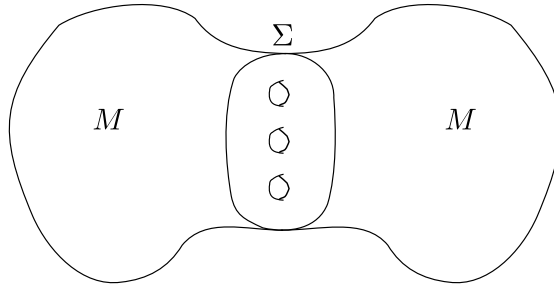

Figure 2.1: M doubled along Σ

Lemma 2.6. *Let G be a group and $H < G$ a subgroup. If $G *_H G$ is residually finite, then G is H -separable.*

This proof is due to Long, upon whose gravestone it is rumored it will be written: “Long was a man of involutions.”

Proof. Let $\Gamma = G *_H G$. Note that Γ admits an involution $\tau : \Gamma \rightarrow \Gamma$ by “flipping” the left and right copies of G . The fixed point set of τ is $\text{Fix}(\tau) = H$ (by the theory of amalgamated products). Let $g \in G \setminus H$, so $\tau(g) \neq g$. Then $g\tau(g^{-1}) \neq 1$ in Γ . Since Γ is residually finite, there exists a finite quotient of Γ , $\varphi : \Gamma \rightarrow A$, such that $\varphi(g\tau(g)^{-1}) \neq 1$ in A . Thus, $\varphi(g) \neq \varphi(\tau(g))$.

Now define $\Phi : \Gamma \rightarrow A \times A$ by $\Phi(\gamma) = (\varphi(\gamma), \varphi(\tau(\gamma)))$. Then $\Phi(H) = (\varphi(H), \varphi(H))$, the diagonal, but $\Phi(g) = (\varphi(g), \varphi(\tau(g))) \notin \Phi(H)$, so G is H -separable by the restriction of Φ to G . \square

Note that if a group G is LERF, then any subgroup $H < G$ is also LERF. Additionally (but not so trivially), groups containing LERF groups as finite index subgroups are LERF.

Lemma 2.7. *Let K be a group, and $G < K$ a finite index subgroup. If G is LERF, then so is K .*

Proof. By the preceding remark, we may assume that $G \triangleleft K$, since the core of G in K is finite index in G and normal in K . Let $p : K \rightarrow K/G$ be the quotient map, let $S \subset K$ be finitely generated, and pick $k \in K \setminus S$. Let $K_1 = p^{-1}(p(S))$. If $k \notin K_1$, we are done since K_1 is finite index in K , so we assume $k \in K_1$.

Then $k = gs$ for some $g \in G$ and $s \in S$ with $g \notin G \cap S$. Since S is finitely generated and $G \cap S$ has finite index in S , we have that $S \cap G$ is a finitely generated subgroup of G . Since G is LERF, there exists $G_2 < G$ of finite index with $g \notin G_2$. Let $G_3 = \bigcap_{s \in S} sG_2s^{-1}$.

Note that $S \cap G < G_2$ and $S \cap G \triangleleft S$, so $S \cap G < sG_2s^{-1}$ for all $s \in S$. Thus, $S \cap G < G_3$. Since $G \triangleleft K$, $sG_2s^{-1} < G$ of finite index for each $s \in S$. Therefore, $G_3 < G$ is finite index (see Figure 2.2).

Let $K_3 = \langle G_3, S \rangle$. Since S normalizes G_3 , $K_3 = G_3 \cdot S$.

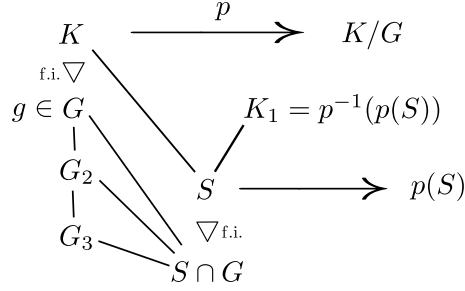

Figure 2.2: The groups in the proof of Lemma 2.7

Claim. $[K : K_3] < \infty$.

To see that the claim is true, consider the second isomorphism theorem:

$$\frac{K_3}{G_3} \cong \frac{G_3 \cdot S}{G_3} \cong \frac{S}{G_3 \cap S}.$$

Since $S/S \cap G$ is finite, $[K : G_3] < \infty$, so $[K : K_3] < \infty$.

Since $S < K_3$, we are done if $k \notin K_3$. If $k \in K_3$, then $gs \in K_3$, so $gs \in K_3$, hence $g \in K_3$ since $S < K_3$. But $g = g_0s_0$ for some $g_0 \in G_3$ and $s_0 \in S$, so $s_0 \in G$, hence $s_0 \in G \cap S$. Since $G \cap S < G_3$, this implies that $s_0 \in G_3$, so $g \in G_3$, which is a contradiction. \square

Next, we note that LERF is more powerful than residually finite.

Definition. For any groups G and A , we say that A is *involved* in G if there exists a finite index subgroup $H < G$ such that H surjects onto A .

Lemma 2.8. Let G be LERF, and assume that $F_2 < G$. Then all finite groups are involved in G .

Proof. Let A be a finite group, let the subgroup H of G be free, and suppose $\varphi : H \twoheadrightarrow A$ is a surjection. Denote by K the Kernel of φ . We assume the following result, which is left to the reader.

Exercise. There exists a finite index subgroup $G_1 < G$ such that $G_1 \cap H = K$.

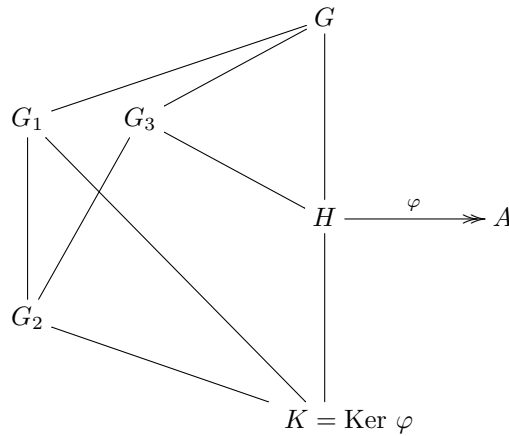

Let $G_2 = \bigcap_{h \in H} hG_1h^{-1}$. From the exercise, we have that $K < G_1$, and we see that $hKh^{-1} = K$, so $K < G_2$ with $[G : G_2] < \infty$. Consider $G_3 = \langle G_2, H \rangle = G_2 \cdot H$. Then, again by the second isomorphism theorem,

$$\frac{G_3}{G_2} \cong \frac{G_2 \cdot H}{H} \cong \frac{H}{H \cap G_2} \cong \frac{H}{K} \cong A.$$

□

We now examine a class of groups which are not LERF. Mennicke and Bass–Milnor–Serre showed that $SL_n(\mathbb{Z})$ has the *congruence subgroup property*, i.e., any finite index subgroup $\Gamma < SL_n(\mathbb{Z})$ contains a principal congruence subgroup $\Gamma(m) = \text{Ker}(SL_n(\mathbb{Z}) \rightarrow SL_n(\mathbb{Z}/m\mathbb{Z}))$.

Theorem 2.9. *For $n \geq 3$, $SL_n(\mathbb{Z})$ is not LERF.*

Proof. By the above lemma, and the observation that $SL_n(\mathbb{Z})$ contains a copy of F_2 , it suffices to show that not all finite groups are involved in $SL_n(\mathbb{Z})$ for $n \geq 3$. Suppose that $SL_n(\mathbb{Z})$ is LERF. Then every finite group is involved in it, so a subgroup Γ_G surjects onto G for all finite groups G . Since $SL_n(\mathbb{Z})$ has the congruence subgroup property, $K = \text{Ker } \theta$ contains $\Gamma(m)$ for some m .

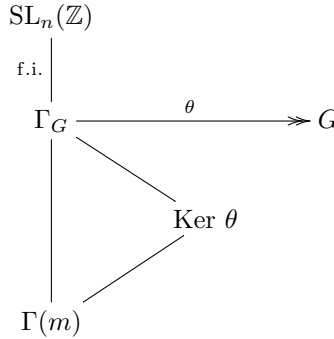

We next employ the fact that for a prime p and a fixed n , if A_l is a quotient of a subgroup of $SL_n(\mathbb{F}_p)$, then $N \geq (2l - 6)/3$. So we can choose $G = A_l$, for a very large l . If $m = p$, then we are done. If not, there is a little more to be said.

If $m = p_1^{m_1} \cdots p_r^{m_r}$, then

$$SL_n(\mathbb{Z}/m\mathbb{Z}) = \prod_{i=1}^n SL_n(\mathbb{Z}/p_i^{r_i}\mathbb{Z}).$$

We next see that the kernel of the map $SL_n(\mathbb{Z}/p_i^{r_i}\mathbb{Z}) \rightarrow SL_n(\mathbb{Z}/p_i\mathbb{Z})$ is a p -group, hence nilpotent. The remaining steps are left as an exercise. □

We now return to 3-manifolds. Scott proved that the fundamental group of a Seifert-fibered space is LERF and that if M is modelled on SOL, then $\pi_1 M$ is LERF. These two facts together show that non-hyperbolic geometric manifolds are LERF. However, there do exist non-compact 3-manifolds that are not LERF.

Example. Let $M = M_\varphi$ be a punctured torus bundle over the circle (see Figure 2.3) with monodromy $\varphi = \begin{pmatrix} 1 & 1 \\ 0 & 1 \end{pmatrix}$. Then $\pi_1 M_\varphi$ is not LERF. Every known 3-manifold that is not LERF is related in some fashion to this example (Burns, Karrass–Solitar).

Conjecture. If M is hyperbolic and $\pi_1 M$ is finitely generated, then $\pi_1 M$ is LERF.

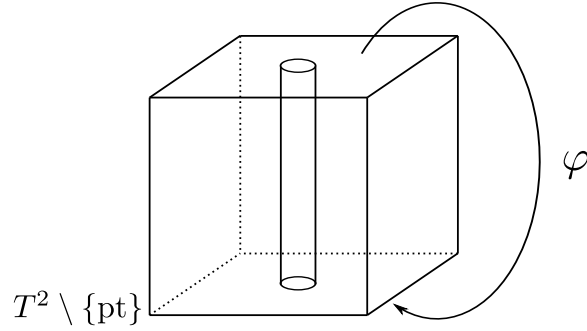

Figure 2.3: The punctured torus bundle over the circle with monodromy φ

Now, let X be a “reasonable topological space,” suited for the theory of universal covering spaces, so that $\pi_1 X = G$ acts properly discontinuously on the universal cover \tilde{X} . Let $H < G$. Then G is H -separable if and only if for all compact subsets $C \subset \tilde{X}/H$, there exists a finite sheeted cover X_C of X such that C projects homeomorphically into X_C (see Figure 2.4).

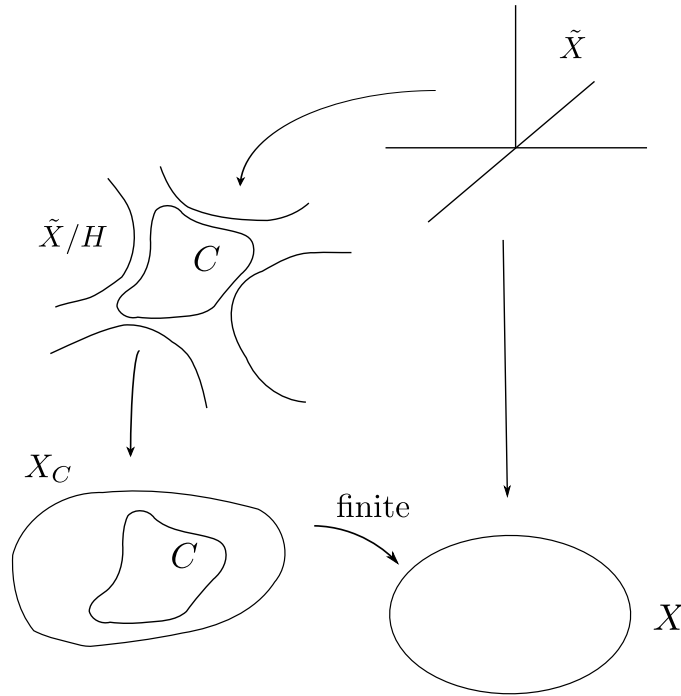

Figure 2.4: C projects homeomorphically to the finite-sheeted cover X_C

The proof of this is an exercise to be included in the notes.

Corollary 2.10. *Let M be a closed, orientable, irreducible 3-manifold, and suppose that $f : \Sigma_g \looparrowright M$ is the topological inclusion of a genus $g \geq 1$ surface into M with $f_* : \pi_1 \Sigma_g \rightarrow \pi_1 M$ injective. Let $\Gamma = \pi_1 M$ and $F = f_*(\pi_1 \Sigma_g)$. If Γ is F -separable, then M is virtually Haken.*

Proof. We can use Scott’s topological reformulation of subgroup separability to pass to a finite cover N of M which corresponds to F . By the Scott Core Theorem, there exists a compact submanifold $C \subset N$ such

that $i_* : \pi_1 C \rightarrow \pi_1 N$ (or $\pi_1 \Sigma_g$) is an isomorphism. Therefore, there exists a finite cover $M_C \rightarrow M$ such that C projects homeomorphically (see Figure 2.5). Thus, M_C contains an embedded incompressible surface. \square

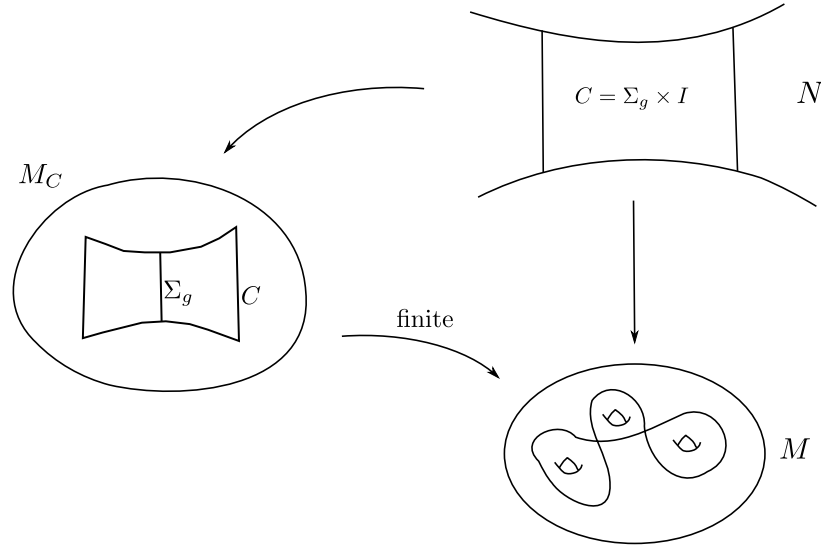

Figure 2.5: C projects homeomorphically to the finite-sheeted cover M_C

- Remarks.**
1. Given Geometrization, the above is of most interest when M is hyperbolic.
 2. Recent work of Kahn-Markovic implies that surface subgroups $f : \Sigma_{g \geq 1} \looparrowright M$ exist for M hyperbolic. Thus, at present the task is to separate these surface groups.

Example. Let $M = M_\varphi$ be a surface bundle over S^1 , and F the fiber group. Then $\Gamma = \pi_1(M_\varphi)$ is F -separable.

Proof. From the bundle we see the short exact sequence

$$1 \longrightarrow F \longrightarrow \Gamma \longrightarrow \mathbb{Z} \longrightarrow 1,$$

where $\Gamma = \langle F, t \mid \text{relations} \rangle$. So given $\gamma \in \Gamma \setminus F$, we have $\gamma = t^n f$. Consider the maps

$$\Gamma \xrightarrow{\varphi} \mathbb{Z} \xrightarrow{\varphi_m} \mathbb{Z}/m\mathbb{Z}.$$

We can compose φ with some φ_m so that $\varphi_m \varphi(\gamma) \neq 1$. \square

Totally geodesic surfaces

Definition. Let $M = \mathbb{H}^3/\Gamma$ closed, orientable. Assume that $f : \Sigma \looparrowright M$ is as above. Then Σ (or $f(\Sigma)$) is *totally geodesic* if the preimage of Σ in \mathbb{H}^3 consists of genuine hyperbolic planes, i.e., consists of planes and hemispheres in \mathbb{H}^3 with the restriction of the hyperbolic metric (See Figure 2.6).

Equivalently, since $\text{PSL}_2(\mathbb{C})$ acts transitively on the set of circles/straight lines in $\hat{\mathbb{C}}$, Σ is totally geodesic if and only if F is Fuchsian (i.e., conjugate to a discrete subgroup of $\text{PSL}_2(\mathbb{R})$).

Let $\Gamma \supset F$ (as above) and F Fuchsian. F preserves a circle (or straight line) in \mathbb{C} , say \mathcal{C} . Consider $H = H_{\mathcal{C}} = \text{Stab}(\mathcal{C}, \Gamma) = \{\gamma \in \Gamma : \gamma \mathcal{C} = \mathcal{C}\}$.

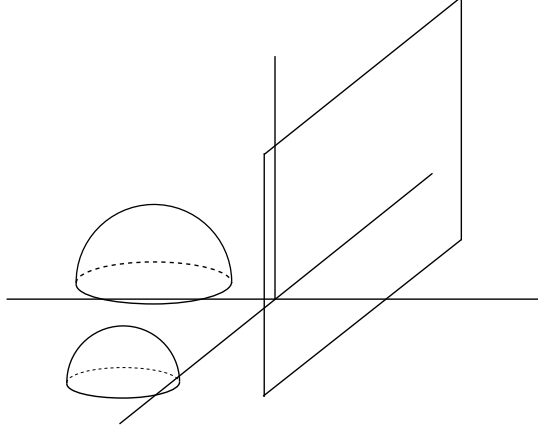

Figure 2.6: The preimage of Σ consists of totally geodesic planes in \mathbb{H}^3

Example. $\mathrm{PSL}_2(\mathbb{Z}) \subset \mathrm{PSL}_2(\mathbb{Z}[i])$, and $\mathrm{Stab}(\mathbb{R}) \subset \mathrm{PSL}_2(\mathbb{Z}[i])$ includes

$$\delta = \begin{pmatrix} i & 0 \\ 0 & -i \end{pmatrix},$$

which acts on \mathbb{C} via $z \mapsto -z$. Thus δ flips components of $\mathbb{C} \setminus \mathbb{R}$.

The stabilizer group H could contain elements that act by reversing orientation on the hyperbolic plane \mathcal{H} , and so H could be a discrete group of isometries with \mathcal{H}/H a (totally geodesic) non-orientable surface.

Theorem 2.11 (Long). *In the notation above*

- (1) Γ is H -separable;
- (2) M is virtually Haken.

Proof. Assume (1) holds. If H corresponds to a Fuchsian group, then we can apply Corollary 2.10 to get virtually Haken. If H is not Fuchsian, by the topological reformulation of H -separability, there exists a finite cover $N \rightarrow M$ for which N contains an embedded, totally geodesic, non-orientable surface. By HW3 Q5, M is virtually Haken.

To prove (1), conjugate Γ so that F leaves invariant $\mathbb{R} \cup \{\infty\}$ (i.e., $F < \mathrm{PSL}_2(\mathbb{R})$). Similarly, H leaves invariant this $\mathbb{R} \cup \{\infty\}$. Let $\gamma \in \Gamma \setminus H$ and let c denote complex conjugation. Consider the matrix $\gamma - c(\gamma)$; since $\gamma \notin \mathrm{PSL}_2(\mathbb{R})$, there is some entry which is not 0. Let x be such an entry and \mathcal{R} be the ring generated by 1, the entries of generators of Γ and their conjugates. As before, there exists a maximal ideal \mathcal{M} such that $x \notin \mathcal{M}$. Let

$$\pi : \Gamma \rightarrow \mathrm{PSL}_2(\mathcal{R}/\mathcal{M}).$$

Define

$$\Phi : \Gamma \rightarrow \mathrm{PSL}_2(\mathcal{R}/\mathcal{M}) \times \mathrm{PSL}_2(\mathcal{R}/\mathcal{M})$$

by $\Phi(\delta) = (\pi(\delta), \pi(c(\delta)))$. Note that $\Phi(H) = (\pi(H), \pi(H))$, but $\Phi(\gamma) \neq \Phi(H)$, by choice of \mathcal{M} . \square

Theorem 2.12. *Let M be a closed, orientable, irreducible 3-manifold and $f : \Sigma \looparrowright M$ which is π_1 -injective. Let $\pi_1 M = \Gamma$ and $F = f_*(\pi_1 \Sigma)$. Suppose that Σ is not a virtual fiber; that is, there exists no finite cover $N \rightarrow M$ such that Σ is a fiber of N . If Γ is F -separable, then Γ is large.*

Proof. Since Γ is F -separable, there exists a finite cover $N \rightarrow M$ for which F lifts to an embedding \tilde{f} (see below). Thus, N is Haken.

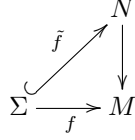

Let $\Gamma_1 = \pi_1 N$. We have two cases:

Case 1: Σ is separating, i.e., $\Gamma_1 = A *_F B$ (see Figure 2.7).

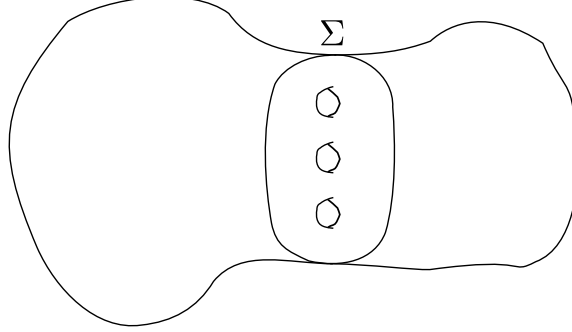

Figure 2.7: Σ separates N

Claim. $[A : F], [B : F]$ cannot both be 2.

Proof. If $[A : F] = [B : F] = 2$, then F is normal in both A and B , and so $F \triangleleft \Gamma_1$. Moreover, $A/F \cong B/F \cong \mathbb{Z}/2\mathbb{Z}$. We then have

$$\varphi : \Gamma_1 \rightarrow \mathbb{Z}/2\mathbb{Z} * \mathbb{Z}/2\mathbb{Z}$$

with $\text{Ker } \varphi = F$ (by HW 3). Hence there exists $\Gamma_2 < \Gamma_1$ such that $\Gamma_2 \rightarrow \mathbb{Z}$ with kernel F .

[Window: Stallings' work implies that Σ is a fiber in a fibration over S^1]

This is contrary to the hypothesis. Therefore at least one of $[A : F], [B : F] \geq 3$. \square

Claim. Assume $[A : F] \geq 3$. Then there exist $a_1, a_2 \in A \setminus F$ (not necessarily distinct) such that $a_1 a_2 \in A \setminus F$.

Proof. Uses elementary group theory. Suppose for the sake of contradiction that $aa' \in F \forall a, a' \in A \setminus F$. Fix a coset decomposition

$$A = F \cup a_1 F \cup a_2 F \cup \dots \cup a_r F \cup \dots,$$

choose a_j and consider $a_j^{-1} a_i F$. Then $a_j^{-1} a_i F = F$ implies that $a_j F = a_i F$, and then $A = F \cup a_j F$, contradicting $[A : F] \geq 3$. \square

Now, Γ being F -separable implies that Γ_1 is F -separable and so we can find $\varphi : \Gamma \rightarrow G$, for a finite group G . Using the second claim above, there exist $a_1, a_2 \in A \setminus F$ such that $\varphi(a_1) \notin \varphi(F), \varphi(a_2) \notin \varphi(F), \varphi(a_1 a_2) \notin \varphi(F)$, and for some $b \in B \setminus F, \varphi(b) \notin \varphi(F)$. Now let $\bar{A} = \varphi(A), \bar{B} = \varphi(B), \bar{F} = \varphi(F)$. Hence we obtain $\bar{\varphi} : \Gamma_1 \rightarrow \bar{A} *_F \bar{B}$. To get largeness one needs to check that $[\bar{A} : \bar{F}] \geq 3$.

Claim. $[\bar{A} : \bar{F}] \geq 3$.

Proof. If $[\bar{A} : \bar{F}] = 2$ then $\bar{A} = \bar{F} \cup \bar{a}_1 \bar{F}, \bar{a}_1 = \varphi(a_1)$. Then $\varphi(a_1 a_2) = \bar{a}_1 \bar{a}_2 \notin \varphi(F) = \bar{F}$. Therefore $\bar{a}_1 \bar{a}_2 \in \bar{a}_1 \bar{F}$, which implies $\bar{a}_2 \in \bar{F}$, a contradiction. \square

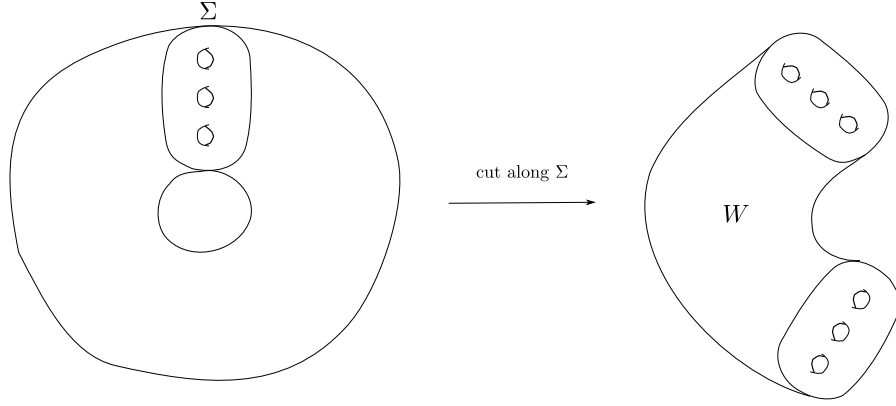
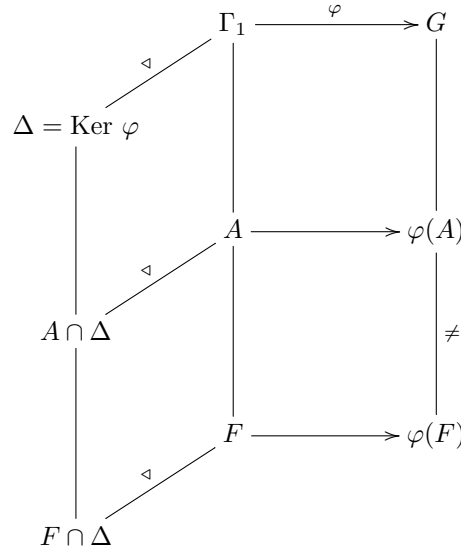

Figure 2.8: Σ does not separate N

Case 2: Σ is non-separating (see Figure 2.8).

Let W denote N cut open along Σ , and notice that $F < A = \pi_1(W) < \pi_1(N) = \Gamma_1$. Since Σ is not a fiber, $W \neq \Sigma \times I$, and so $A \neq F$. Since Γ is F -separable, Γ_1 is F -separable, and so if $a \in A \setminus F$ we can find $\varphi : \Gamma_1 \rightarrow G$, for some finite group G , such that $\varphi(a) \notin \varphi(F)$.



Let $\Delta = \text{Ker } \varphi$ and consider the finite cover $M_\Delta \rightarrow N$ corresponding to Δ . This induces a covering $W_\Delta \rightarrow W$ (see Figure 2.9).

Since $\varphi(A) \neq \varphi(F)$, the number of components in the preimage of Σ in W_Δ is greater than 1. Now construct a cover M_Δ from copies of W_Δ (see Figure 2.10).

Then if S_1, S_2 are two components of the preimage of Σ , then $M_\Delta \setminus (S_1 \cup S_2)$ is connected. We may therefore apply HW3 Q1 to reach the desired conclusion. \square

Remark. Case 1 can be reduced to Case 2 by similar argument. One can construct a cover of N for which $b_1 > 0$.

Note that Γ being F -separable (for F a surface group) implies that F is contained in infinitely many subgroups of finite index in Γ .

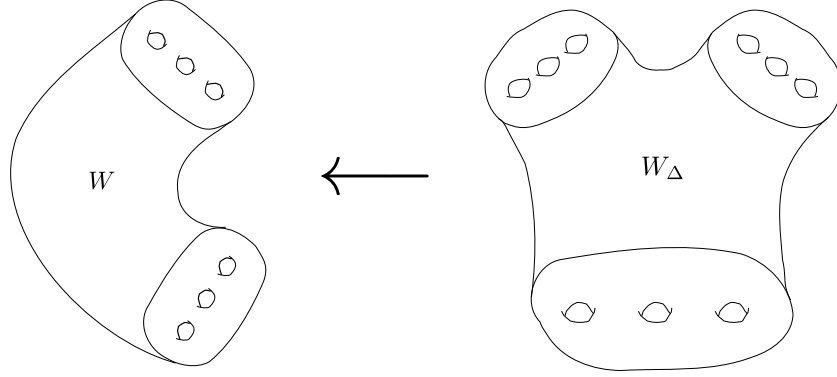

Figure 2.9: The cover W_Δ

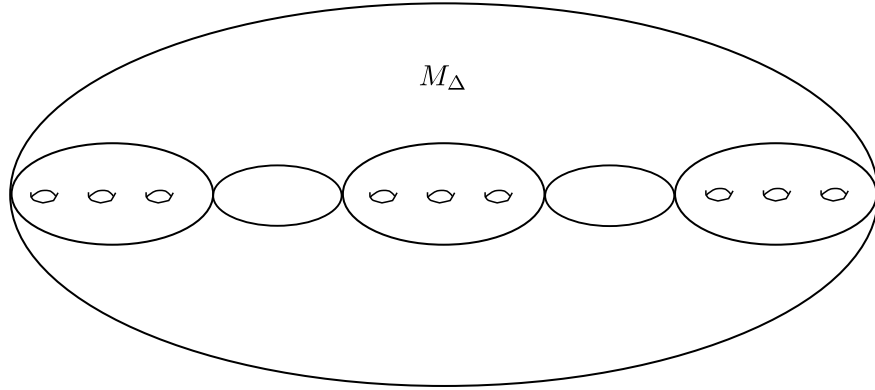

Figure 2.10: The cover M_Δ of W_Δ

Theorem 2.13 (Jaco). *Let M be a closed, orientable, irreducible 3-manifold. Let $f : \Sigma_{g \geq 1} \rightarrow M$ be π_1 -injective with $F = f_*(\pi_1(\Sigma_g)) < \Gamma = \pi_1(M)$. Assume F is contained in infinitely many subgroups of Γ of finite index. Then M is virtually Haken.*

Proof. □

Corollary 2.14. *Let $M = \mathbb{H}^3/\Gamma$ be closed and orientable. Let $f : \Sigma_g \rightarrow M$ be π_1 -injective and $F = f_*(\pi_1(\Sigma_g))$. Suppose that for some prime p , the rank $\text{rk}(H_1(M; \mathbb{F}_p)) \geq 2g + 2$. Then M is virtually Haken.*

Proof. Let \mathcal{S} be the set of subgroups $\Delta < \Gamma$ satisfying

- (1) $[\Gamma : \Delta] < \infty$;
- (2) $\text{rk}(H_1(\Delta; \mathbb{F}_p)) = \text{rk}(H_1(\mathbb{H}^3/\Delta; \mathbb{F}_p)) \geq 2g + 2$;
- (3) $F < \Delta$.

If we can show \mathcal{S} is infinite, then Theorem 2.13 applies. Note that $\mathcal{S} \neq \emptyset$ because $\Gamma \in \mathcal{S}$. To show that \mathcal{S} is infinite, we will show that if $\Delta \in \mathcal{S}$, then there exists $D \subsetneq \Delta$ of finite index with $D \in \mathcal{S}$.

Definition. Let G be a finitely generated group. The *mod p lower central series* of G is defined as follows:

$$\begin{aligned}
G_0 &= G; \\
G_1 &= [G, G] \cdot G^p; \\
G_{i+1} &= [G, G_i] \cdot G_i^p.
\end{aligned}$$

We have $G/G_1 \cong H_1(G; \mathbb{F}_p)$, and G_i/G_{i+1} is an elementary abelian p -group.

Now let $\Delta \in \mathcal{S}$ and consider $D = F \cdot \Delta$. We have $[\Delta : D] < \infty$. Note that

$$\varphi : \Delta \longrightarrow \Delta/\Delta_1 \cong (\mathbb{Z}/p\mathbb{Z})^r,$$

for some $r \geq 2g + 2$. Now $\varphi(F)$ does not surject, and so $D = \varphi^{-1}\varphi(F)$ is a proper subgroup of finite index. We are done if D satisfies the following condition on H_1 .

Claim. $\text{rk}(H_1(D; \mathbb{F}_p)) \geq 4g + 1$ ($> 2g + 2$).

Lemma 2.15.

(1) Let Γ be a finitely generated group and $E < \Gamma$ be generated by n elements. Then

$$\text{rk}(H_1(E.\Gamma_1; \mathbb{F}_p)) \geq \text{rk}(\Gamma_1/\Gamma_2) - \frac{n(n-1)}{2};$$

(2) Let M be as in Corollary 2.14. Let $r = \text{rk}(H_1(\Gamma; \mathbb{F}_p)) = \text{rk}(H_1(M; \mathbb{F}_p))$. Then

$$\text{rk}(\Gamma_1/\Gamma_2) \geq \frac{1}{2}r(r-1).$$

We apply these inequalities to $D = F.\Delta_1$.

(1) implies

$$\text{rk}(H_1(D; \mathbb{F}_p)) \geq \text{rk}(\Delta_1/\Delta_2) - \frac{1}{2}2g(2g-1);$$

(2) implies

$$\text{rk}(H_1(D; \mathbb{F}_p)) \geq \frac{1}{2}(2g+2)(2g+1) - \frac{1}{2}2g(2g-1) = 4g+1.$$

This proves the Claim, and hence Corollary 2.14. \square

We next aim to show:

Theorem 2.16. *There exist closed, orientable (resp. finite volume, orientable) hyperbolic 3-manifolds \mathbb{H}^3/Γ for which Γ is LERF.*

Notation and Terminology:

By a *Kleinian group*, we mean a discrete subgroup of $\text{PSL}_2(\mathbb{C})$.

Let Γ be a Kleinian group. Denote by $\Lambda_\Gamma \subset \hat{\mathbb{C}}$ the *limit set* of Γ ; that is, Λ_Γ is the collection of accumulation points of Γ -orbits in \mathbb{H}^3 . Let $x \in \mathbb{H}^3$ be any point, consider those $y = \lim \gamma_i x$, for $\gamma_i \in \Gamma$. This is also the closure of set of fixed points of elements of infinite order in Γ . See Homework 3 for properties of Λ_Γ .

The set $\Omega_\Gamma = \hat{\mathbb{C}} \setminus \Lambda_\Gamma$ is called the *domain of discontinuity* of Γ . It may be that $\Omega_\Gamma = \emptyset$.

Define $C(\Lambda_\Gamma)$ to be the *convex hull* of Λ in $\mathbb{H}^3 \cup \hat{\mathbb{C}} = \overline{\mathbb{H}^3}$; that is, $C(\Lambda_\Gamma)$ is the intersection of all convex subsets of $\overline{\mathbb{H}^3}$ that contain Λ . In a slight abuse of notation, we also think of $C(\Lambda_\Gamma) \subset \mathbb{H}^3$. From Lemma 2.17 below, $C(\Lambda_\Gamma)$ is Γ -invariant, and thus we may form $C(\Lambda_\Gamma)/\Gamma \subset \mathbb{H}^3/\Gamma$, which is called the *convex core*.

Lemma 2.17. *The convex hull of Λ , $C(\Lambda_\Gamma)$, is Γ -invariant.*

Proof. If $S \subset \overline{\mathbb{H}^3}$ is convex, then $\gamma(S)$ is convex ($\gamma \in \Gamma$). Hence if $\Lambda_\Gamma \subset S$, $\Lambda_\Gamma = \gamma\Lambda_\Gamma \subset \gamma(S)$. □

Examples. 1. Given a Fuchsian group $\Gamma < \text{PSL}_2(\mathbb{R}) \subset \text{PSL}_2(\mathbb{C})$ with \mathbb{H}^2/Γ closed, then $\Lambda_\Gamma = \mathbb{R} \cup \{\infty\}$, and $C(\Lambda_\Gamma) = \mathbb{H}^2$, the x - z plane (see Figure 2.11). In this case, $\mathbb{H}^2/\Gamma = C(\Lambda_\Gamma)/\Gamma$ is a surface inside \mathbb{H}^3/Γ .

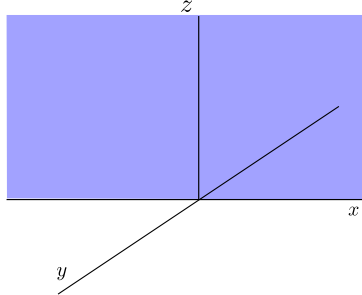

Figure 2.11: $\Gamma < \text{PSL}_2(\mathbb{R})$ acts on the x - z plane $\mathbb{H}^2 \subset \mathbb{H}^3$

2. Let $F \triangleleft \Gamma = \pi_1 M^3$ and F be a fiber group. Then we have $\Lambda_F = \hat{\mathbb{C}}$, $C(\Lambda_F) = \mathbb{H}^3$, and $C(\Lambda_F)/F = \mathbb{H}^3/F$.

Definition. A Kleinian group $\Gamma < \text{PSL}_2(\mathbb{C})$ is called *geometrically finite* if for all $\varepsilon > 0$,

$$\text{Vol}(N_\varepsilon(C(\Lambda_\Gamma)/\Gamma)) < \infty$$

where N_ε denotes the regular ε -neighborhood. Otherwise, Γ is called *geometrically infinite*.

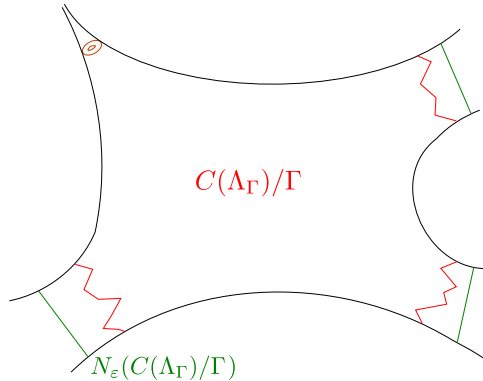

Figure 2.12: The convex core $C(\Lambda_\Gamma)/\Gamma \subset \mathbb{H}^3/\Gamma$

Definition. Let $\Gamma < \text{Isom}(\mathbb{H}^3)$. The group Γ is called *GFERF* if Γ is H -separable for all geometrically finite subgroups $H < \Gamma$.

Remark. Since geometrical finiteness is preserved by subgroups and supergroups of finite index, the same is true of GFERF.

Theorem 2.18. Let $P \subset \mathbb{H}^3$ be a polyhedron in \mathbb{H}^3 of finite volume, all of whose dihedral angles are $\frac{\pi}{2}$. Let $G(P)$ be the group generated by reflections in the faces of P . Then $G(P)$ is GFERF.

Corollary 2.19. If $\Gamma < G(P)$ of finite index, then Γ is GFERF.

Example. Löbell manifolds, $L(n)$ for $n \geq 5$. Consider a polyhedron with two n -gon faces and $2n$ pentagonal faces arranged as follows (see Figure 2.13).

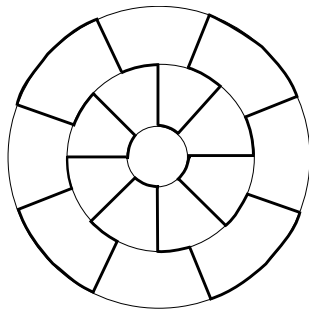

Figure 2.13: The Löbell polyhedron $L(8)$ with Hamiltonian cycle

Consider the group $G(P)$ generated by reflections in this polyhedron. The index 2 orientation-preserving subgroup corresponds to a 2-fold cover which is a link in S^3 labeled by 2's; the double cover of this is a link complement.

Exercise. Let Γ be RF, $H < \Gamma$ a finite subgroup. Then Γ is H -separable.

Idea of Proof of 2.18: Let $\Gamma = G(P)$, where P is compact, and $H < \Gamma$ some geometrically finite subgroup. Let X be a compact subset of $C(\Lambda_H)/H$. There exists a compact $X_1 \subset C(\Lambda_H)$ such that the image of X_1 under the natural projection p (see Figure 2.14) is X in $C(\Lambda_H)/H$. Furthermore, let \mathcal{F} be the set of hyperplanes in \mathbb{H}^3 that arise as Γ -images of the hyperplanes spanned by the faces of P .

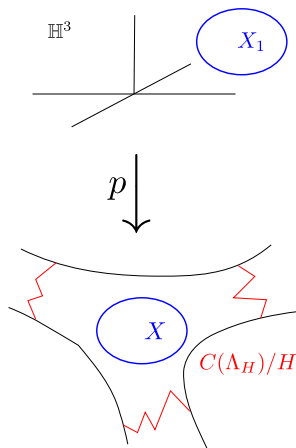

Figure 2.14: X_1 projects to X

Take \bar{Y} to be the intersection of all closed half-spaces that contain $C(\Lambda_H)$ in their interior and such that their bounding hyperplane lies in \mathcal{F} . We see that \bar{Y} is convex, and note \bar{Y} is H -invariant (this is because if U is half-space that contributes to \bar{Y} , then with $U \supset C(\Lambda_H)$, $hU \supset hC(\Lambda_H) = C(\Lambda_H)$). Now set $K(\bar{Y})$

to be the group generated by reflections in faces of \bar{Y} . The group $K(\bar{Y})$ is discrete, and \bar{Y} is a fundamental polyhedron for its action. Note that H normalizes $K(\bar{Y})$. Let $K_1 = \langle K(\bar{Y}), H \rangle = K(\bar{Y}).H$. Consider $\mathbb{H}^3/K_1 = \bar{Y}/H$, which yields:

Claim. \bar{Y}/H is compact (resp. finite volume).

Warm-up Case for Theorem 2.18

We will consider an all-right pentagon, P , with edges $\{e_1, \dots, e_5\}$ in \mathbb{H}^2 . Let $\Gamma = G(P)$, H be a finitely generated subgroup of Γ , $C = C(\Lambda_H)$, and $X \subset \mathbb{H}^2/H$ be compact. Note that C/H is compact (as H contains no parabolic isometries, because P is compact), so $N_\varepsilon(C/H)$ is compact. Thus there exists $t > 0$ such that every point of X is within t of $N_\varepsilon(C/H)$. Now set C^+ to be the $10t$ neighborhood of C in \mathbb{H}^2 . Note C^+ is still convex and H -invariant (for $x \in C^+$, $d(hx, C) = d(hx, hC) = d(x, C) \leq 10t$ for $h \in H$). Moreover, C^+ projects into \mathbb{H}^2/H to give a larger compact set containing X .

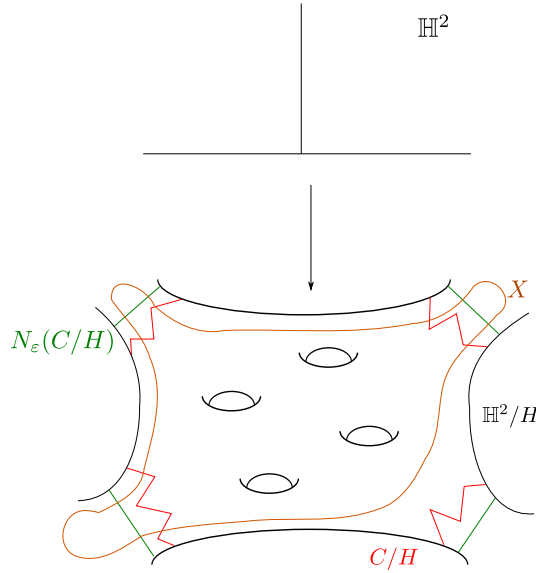

Figure 2.15: The compact set $X \subset \mathbb{H}^2/H$

Now, following the *Idea of Proof of 2.18*, set \mathcal{F} to be the set of hyperplanes (geodesic lines) in \mathbb{H}^2 that arise as Γ -images of the hyperplanes spanned by the edges e_i of P , and \bar{Y} to be the intersection of all closed half-spaces that contain C^+ in their interior and with boundary in \mathcal{F} . We get

Claim. \bar{Y}/H is compact; that is, \bar{Y}/H involves finitely many P -tiles.

Remarks. First, note that \bar{Y} is the smallest convex union of pentagons that contains C^+ in its interior; furthermore, if there exists a hyperplane $W \in \mathcal{F}$ such that W separates a P -tile from C^+ , then this P -tile cannot lie in \bar{Y} (faces of such meet C^+) (see Figure 2.16). The idea is that P -tiles sufficiently far from C^+ do not lie in \bar{Y} .

Second, with $K_1 = \langle K(\bar{Y}), H \rangle$, where $K(\bar{Y})$ is group generated by reflections in \bar{Y} , we have $\mathbb{H}^2/K_1 = \bar{Y}/H$. Thus the claim implies $[\Gamma : K_1] < \infty$, yielding the required result.

Example. Consider H cyclic, P^* a P -tile far from C^+ (How far? See Lemma 2.20, below), let a be the closest point of P^* to C^+ , p a point of C^+ closest to a , γ the geodesic between a and p , W_p be the support plane to C^+ at p , and $W_a \in \mathcal{F}$ be the plane containing a (see Figure 2.17). Then W_p and W_a are geodesics meeting γ at right angles and $W_p \cap W_a = \emptyset$; thus we have separated P^* from C^+ using an element of \mathcal{F} .

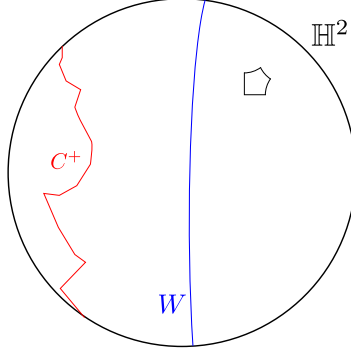

Figure 2.16: The plane W separates C^+ from a P -tile

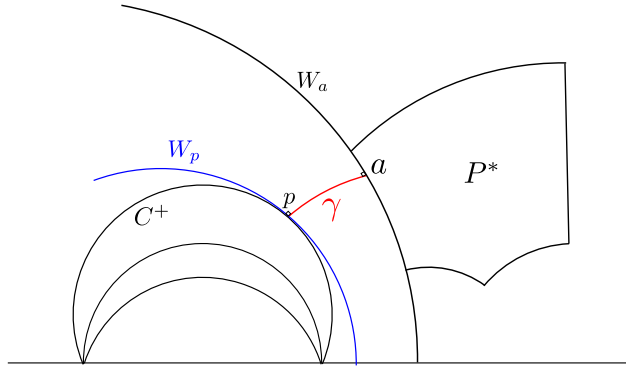

Figure 2.17: C^+ is separated from P^*

Remark. Consider what is different in \mathbb{E}^2 ; with G the group generated by unit translations in the coordinate axes, and the cyclic group $H < G$ generated by $h(x, y) = (x + 1, y)$, what is the smallest convex union of unit squares covering a line?

Lemma 2.20. *Let L be a line in \mathbb{H}^2 and $x \in \mathbb{H}^2 \setminus L$. Then there exists a constant K such that for $x \in \mathbb{H}^2 \setminus L$ where $d(x, L) > K$, the angle $\alpha = \alpha(x, L)$ (that is, the angle subtended by L at x) satisfies $\alpha < \pi/4$.*

Proof. From hyperbolic geometry (see Beardon's book), $\cosh(d(x, y)) \sin(\alpha/2) = 1$, where $y \in L$ such that the geodesic from x to y is orthogonal to L . Now solve for K . □

With the **Example** and **Lemma 2.20** in mind, back to an arbitrary finitely generated H .

For $x_0 \in P$ and $\gamma \in \Gamma$, if γ is such that $P^* = \gamma P$, then set $x^* = \gamma x_0$; we refer to these x^* 's as *basepoints* for the P -tiles. For every support plane W_p for C^+ , there is a K so that $\alpha(x, W_p) < \pi/4$ when $d(x, W_p) > K$ and $x \in \mathbb{H}^2 \setminus W_p$, so set $T = r + K$, where $r = \sup \{d(x_0, z) : z \in \partial P\}$.

Claim. *No P -tile with a basepoint outside $N_T(C^+)$ lies in \bar{Y} .*

Proof. Suppose this is not the case, so assume P^* is a tile whose basepoint lies outside $N_T(C^+)$ and contributes to \bar{Y} . Since P^* meet C^+ , there is some plane $F_1 \in \mathcal{F}$ which contains a face of P^* that meets C^+ . Let F be a hyperplane in \mathcal{F} containing a face of P^* that meets F_1 in a vertex a . We have $d(x^*, C^+) > T$, by assumption. Since $d(x^*, a) \leq r$, $d(a, C^+) > K$. Now let p be the point on C^+ closest to a , and W_p be the supporting hyperplane containing p (see Figure 2.19).

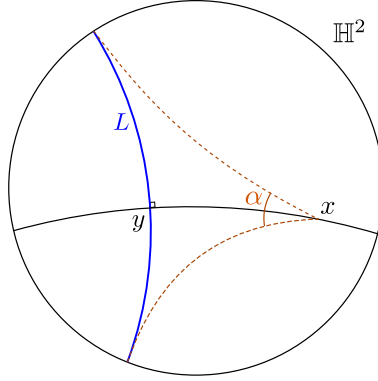

Figure 2.18: α is the angle subtended by L at x

$F \cap W_p = \emptyset$. Note: With $d(a, p') \geq K$ for $p' \in W_p$, the angle subtended by W_p at a is less than $\pi/4$. However, angle of F_1 and F at a is $\pi/2$. So F cannot intersect W_p .

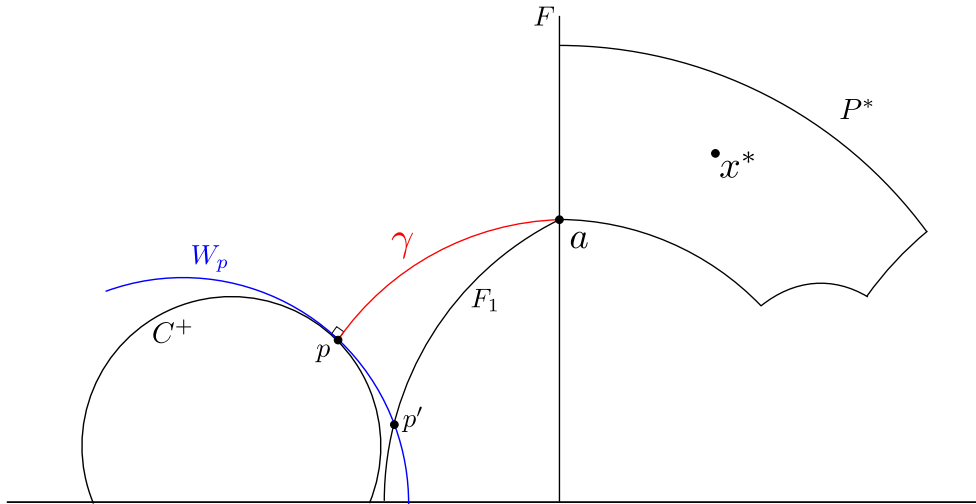

Figure 2.19: F does not intersect W_p

□

We now turn to the 3-dimensional hyperbolic space \mathbb{H}^3 as stated in the theorem.

Proof of 2.18. If P is a compact polyhedron, we will see that the argument proceeds as before. If $H \subset G(P)$ is geometrically finite, we again construct an H -invariant set C^+ . The key claim is that if \bar{Y} is the tiling hull, then \bar{Y}/H consists of finitely many tiles.

Firstly, let P be compact, i.e. all vertices lie in the interior of \mathbb{H}^3 . If P^* is a distant tile, let a^* be a point of P^* closest to C^+ . Then let p be a point of C^+ closest to a^* . If a^* lies in the interior of a face, then the picture we have is as above: there is a plane separating P^* from C^+ . However, it could be that a^* lies in a lower-dimensional face. In this case, since all dihedral angles are equal to $\frac{\pi}{2}$, the geodesic γ must make an angle close to $\frac{\pi}{2}$ with one of the faces. Then the process works as above.

Now suppose P contains an ideal vertex. Set $\Gamma = G(P)$, and let $H < \Gamma$ be geometrically finite. Now H may or may not have parabolic elements; if not, then the convex core is compact, and we proceed as before; if so, then $C(\mathbb{H}^3/H)$ is more complicated.

Consider the groups $\text{Stab}_p(H) = \{h \in H \mid h(p) = p\}$ for a given parabolic fixed point p . If all these groups are virtually isomorphic to $\mathbb{Z} \times \mathbb{Z}$, then it is not difficult to see that only finitely many tiles are involved in the construction. Since $\text{Stab}_p(H)$ is of maximal rank, we have $[\text{Stab}_p(\Gamma) : \text{Stab}_p(H)]$ is finite. Arrange p to be at ∞ in the upper half-space model for \mathbb{H}^3 . Then P and some finite number of copies covers that part of $C(\Lambda_H)/H$. This, combined with the previous argument, implies the finiteness required.

Finally, more is required to deal with the case that for some p , $\text{Stab}_p(H)$ is virtually isomorphic to \mathbb{Z} , although one can show that this can be reduced to the previous case. \square

We have shown that there exist hyperbolic 3-manifolds which are GFERF. However, Theorem 2.16 claimed that there exist examples which are LERF. That is, as well as geometrically finite subgroups, we need to separate finitely generated geometrically infinite subgroups. The key point here is that if Γ is of finite covolume and $H < \Gamma$ is finitely generated and geometrically infinite, then $H \cong \pi_1 F$ for a surface F of finite type, and F is virtually a fiber or a fibration over S^1 . (This uses the solution to the Tameness Conjecture, and work of Canary. The Tameness Conjecture roughly states that the ends of \mathbb{H}^3/H are *tame*; i.e. they are topologically $F \times [0, \infty)$ for a closed surface F .)

Given this background, the idea runs as follows. Firstly, work of Bonahon shows that if the cocompact subgroup $H < \Gamma$ is a surface group, then \mathbb{H}^3/H is tame. Thurston showed that there exists a sequence of “nice” (pleated) surfaces that exit the two ends. Thurston also showed that the space of pleated surfaces

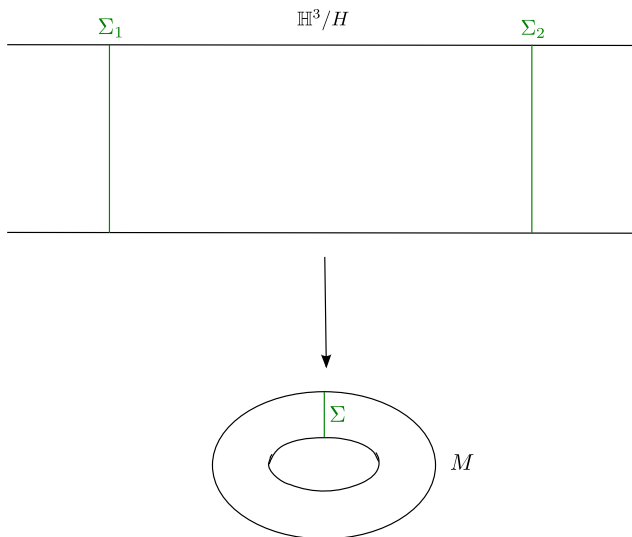

Figure 2.20: Σ_1 and Σ_2 descend to surfaces homotopic to Σ

is compact, and one can find two surfaces Σ_1 and Σ_2 in \mathbb{H}^3/H which are far apart in \mathbb{H}^3/H and close (i.e. homotopic) in M (see Figure 2.20), i.e. there exists a covering translation $t \in \pi_1 M$ taking Σ_1 to Σ_2 . It then follows that $\langle H, t \rangle$ is a bundle with fiber F , and $\pi_1 F \cong H$.

As a consequence of the above, in order to prove that if M^3 is hyperbolic, and either closed or of finite volume, then $\pi_1 M^3$ is LERF, it suffices to prove it is GFERF.

- Remarks.** 1. The “all-right technology” outlined above works in some higher dimensions to prove the existence of lattices that are GFERF. Are these always LERF?
2. The same technology proves that the Bianchi groups $\text{PSL}_2(\mathcal{O}_d)$ are GFERF, where $\mathcal{O}_d \subset \mathbb{Q}(\sqrt{-d})$ is the ring of integers. To prove this, it is shown that for each d , there exists a finite index subgroup

$\Gamma_d < \mathrm{PSL}_2(\mathcal{O}_d)$ such that Γ_d can be embedded in $G(P)$, where $P \subset \mathbb{H}^6$ is a totally geodesic ideal polyhedron.

The all-right technology also shows the following.

Corollary 2.21. *Let $P \subset \mathbb{H}^3$ be a finite volume polyhedron, all of whose dihedral angles are $\frac{\pi}{2}$. Let $H < G(P)$ be geometrically finite. Then H is a virtual retract, i.e. there exists a finite index subgroup $\Gamma_H < G(P)$ such that the following diagram commutes.*

$$\begin{array}{ccc} \Gamma_H & \longrightarrow & H \\ | & \nearrow id & \\ H & & \end{array}$$

Proof. As in the proofs of 2.16 and 2.18, given H , we build a group $K = \Gamma_H = \langle K(\bar{Y}), H \rangle = K(\bar{Y}).H$, where $K(\bar{Y})$ is the group generated by reflections in the faces of \bar{Y} . Importantly, we have that \bar{Y} is a fundamental polyhedron for the action of $K(\bar{Y})$, and by the second isomorphism theorem,

$$\frac{\Gamma_H}{K(\bar{Y})} \cong \frac{H}{K(\bar{Y}) \cap H}.$$

The claim is that $K(\bar{Y}) \cap H = 1$. The $K(\bar{Y})$ -images of \bar{Y} tessellate \mathbb{H}^3 , but Y contains $C(\Lambda_H)$ in its interior, and this is H -invariant. \square

We conclude the discussion of Theorem 2.18 by making some comments on the proof in the case where P has an ideal vertex. Let $W = \{x^* : x^* \text{ is a basepoint of a } P\text{-tile in } \bar{Y}\}$. We have the following:

Claim. *If H is geometrically finite, then the number of orbits of W under H is finite.*

Proof. Recall that there exists a constant $T > 0$ such that $W \subset N_T(C^+)$. If we assume there are infinitely many orbits, what does this assumption mean?

To obtain an answer, observe that an alternative equivalent reformulation of geometrical finiteness (GF) is that $C(\Lambda_H)/H$ decomposes as a union of a compact manifold and a finite disjoint union of cusp neighborhoods. These cusp neighborhoods are projections of horoballs $B_\eta(p)$ for p a parabolic fixed point. Moreover, η can be chosen so that $B_\eta(p) \cap B_\eta(q) = \emptyset$ if $p \neq q$ and so that $B_\eta(p) \cap gB_\eta(p) \neq \emptyset$ implies $g \in \mathrm{Stab}_p H$.

Now we can say that the above assumption means the following. We can subsequence the x^* to get a sequence $x_{n_k}^*$ with the property that “ $x_{n_k}^* \rightarrow p$ ” for some parabolic fixed point p , where $x_{n_k}^* \rightarrow p$ means there exists $\varepsilon_m > 0$ with $x_{n_k}^* \in B_{\varepsilon_m}(p)$ for all but a finite number of $x_{n_k}^*$ (see Figure 2.21). Let $P_{n_k} = \gamma_{n_k}(P)$ be the P -tiles associated to $x_{n_k}^*$.

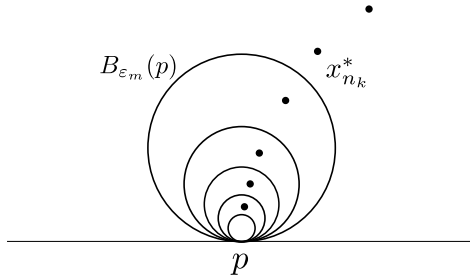

Figure 2.21: The subsequence x_{n_k} goes to p

Exercise. There exists a face F_{n_k} of P_{n_k} such that F_{n_k} does not contain p , i.e. if τ_{n_k} is the reflection in F_{n_k} then $\tau_{n_k}(p) \neq p$.

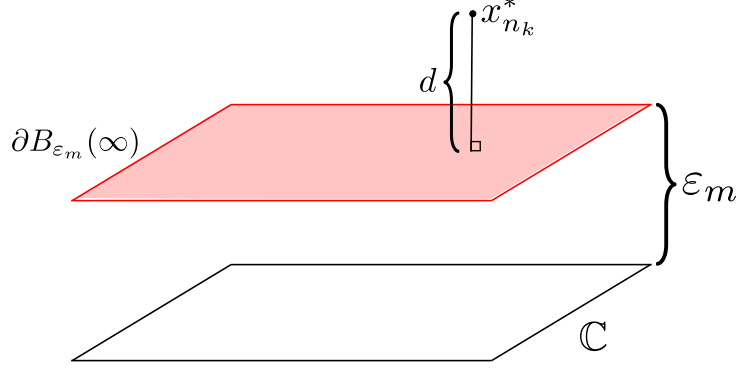
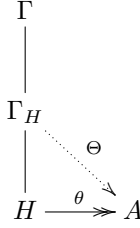

Figure 2.22: d is the distance from $x_{n_k}^*$ to the horosphere $\partial B_{\varepsilon_m}(\infty)$

We normalize so that $p = \infty$, and fix ε_m . Then for sufficiently large k , the horoball $B_{\varepsilon_m}(\infty)$ meets every face of P_{n_k} . We can measure the distance d from $x_{n_k}^*$ to $\partial B_{\varepsilon_m}(\infty)$ (see Figure 2.22). As $x_{n_k}^* \rightarrow p$, then $d \rightarrow \infty$. Let r be the supremum of the distances to the faces of P . If $d \gg 0$ then we exceed r , so we meet every face. Consequently τ_{n_k} , the reflection in F_{n_k} , takes some points of $B_{\varepsilon_m}(\infty) \subset B_\eta(\infty)$ to points in $B_\eta(\infty)$, but $\tau_{n_k} \notin \text{Stab}_p H$, so we reached a contradiction. \square

Recall the following property of LERF: Suppose Γ is LERF and $H < \Gamma$ is finitely generated. Let A be a finite group. The LERF condition implies that there exists $\Gamma_H < \Gamma$ of finite index and a homomorphism $\Theta : \Gamma_H \rightarrow A$ such that $\Theta|_H = \theta$:



Definition. We say a group Γ has the *local extension property* for a class of subgroups \mathcal{C} if for any $H \in \mathcal{C}$ and $\theta : H \rightarrow A$, for A finite, there exists a finite index subgroup $\Gamma_H < \Gamma$ with $\Gamma_H \supset H$ and a surjective map $\Theta : \Gamma_H \rightarrow A$ with $\Theta|_H = \theta$. If $H < \Gamma$, let $\mathcal{A} = \{K < \Gamma : K \text{ is of finite index, } H \subset K\}$. We introduce the notation

$$H^* = \bigcap_{K \in \mathcal{A}} K$$

Theorem 2.22. *Let $M = \mathbb{H}^3/\Gamma$ be a closed, orientable, hyperbolic 3-manifold. Suppose that Γ has the local extension property for geometrically finite subgroups H and homomorphisms $H \rightarrow \mathbb{Z}/2\mathbb{Z}$. Then any geometrically finite subgroup H is almost separable (i.e. $[H^* : H] < \infty$). In particular, if H is a surface group, then M is virtually Haken.*

Proof. We begin with the following:

Claim (1). *There exists an infinite cyclic subgroup C of Γ such that $\langle H, C \rangle \cong H * C$ and $H * C$ is geometrically finite.*

Given Claim 1 and the hypothesis, we have

$$\begin{array}{c} \theta \\ \curvearrowright \\ H * C \longrightarrow C \longrightarrow \mathbb{Z}/2\mathbb{Z}. \end{array}$$

Clearly $H \subset \text{Ker } \theta$, and θ extends to $\Theta : V \rightarrow \mathbb{Z}/2\mathbb{Z}$, where $[\Gamma : V] < \infty$ and $\Theta|_{H * C} = \theta$, and so $H < \text{Ker } \Theta$. Therefore H is engulfed in a proper subgroup of finite index in Γ .

Claim (2). *If Γ has the engulfing property for all geometrically finite subgroups, then $[H^* : H] < \infty$ for all geometrically finite subgroups.*

This will prove Theorem 2.22. To prove Claim 2, it suffices to prove

Claim (2'). $\Lambda_{H^*} = \Lambda_H$.

Given this Claim, we have $C(\Lambda_{H^*}) = C(\Lambda_H)$ and we get a covering map from $N_\varepsilon(C(\Lambda_H)/H)$ (of finite volume by hypothesis) to $N_\varepsilon(C(\Lambda_H)/H^*)$. Hence the index is finite. \square

Proof of Claims 1 and 2'. Let $\gamma \in \text{PSL}_2(\mathbb{C})$ be hyperbolic with fixed points $\partial\gamma = \{a_+, a_-\}$. Let U_\pm be open neighborhoods of a_\pm with $U_+ \cap U_- = \emptyset$. Say (U_+, U_-) is *absorbing* for γ if

- (a) for any $p \in S_\infty^2 \setminus U_-$, $\gamma(p) \in U_+$;
- (b) for any $p \in S_\infty^2 \setminus U_+$, $\gamma^{-1}(p) \in U_-$.

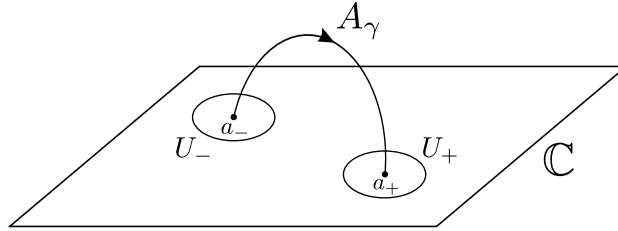

Figure 2.23: a_+ is the attracting fixed point of γ ; a_- is the repelling fixed point

Note that for any disjoint U_+, U_- as above, they will be absorbing for γ^k for some large k . Since $H < \Gamma$ is geometrically finite, $\Lambda_H \subsetneq S_\infty^2$.

Exercise. There exists $\gamma \in \Gamma$ such that $\partial\gamma$ does not lie on Λ_H .

Exercise. $\langle H, \gamma^k \rangle = H * \langle \gamma^k \rangle$ for large k .

The following theorem finishes the proof of Claim 2'. \square

Theorem 2.23. *Let $M = \mathbb{H}^3/\Gamma$ be as in Theorem 2.22. Suppose that Γ has the engulfing property for all geometrically finite subgroups. Then for all finitely generated subgroups H , $\Lambda_{H^*} = \Lambda_H$.*

Definition. We say $A < \Gamma$ is *engulfed* if there exists $K < \Gamma$ of (non-trivial) finite index, such that $A \subset K$.

Proof. Let $H < \Gamma$ be finitely generated. If $\Lambda_H = S_\infty^2$ then $\Lambda_{H^*} = S_\infty^2$, so we can assume that H is geometrically finite. Assume that $\Lambda_H \subsetneq \Lambda_{H^*}$. Let Γ be generated by $\{\gamma_1, \dots, \gamma_n\}$. As before, we can find $\beta_1, \dots, \beta_n \in H^*$ such that:

1. the fixed points $\partial\beta_i$ lie in $\Lambda_{H^*} \setminus \Lambda_H$;

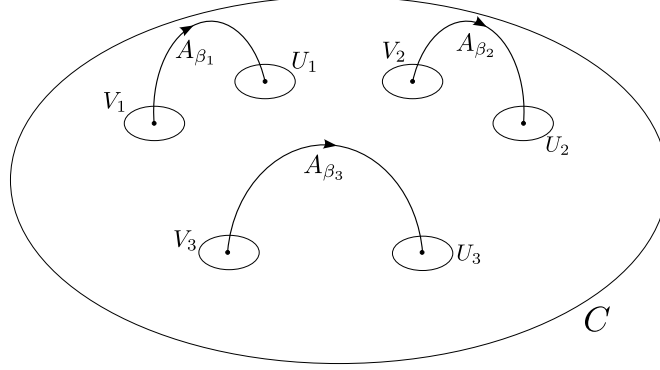

Figure 2.24: The U_i and V_i are neighborhoods of the feet of the axes A_{β_i}

2. $\partial\beta_i \neq \partial\gamma_j$ for any i, j , and $\partial\beta_i \in S_\infty^2 \setminus \Lambda_H = \Omega_H$, the domain of discontinuity.

Let $C \subset \Omega_H$ be a compact set such that $\partial\beta_i$ lies in the interior of C . Since H acts discontinuously on Ω_H , there exist only a finite number of elements $h_1, \dots, h_m \in H$ such that $h_i C \cap C \neq \emptyset$. By residual finiteness, there exists $N \triangleleft H$ of finite index such that $h_i \notin N$ for $i = 1, \dots, m$.

Exercise. There exists $t \in \mathbb{N}$ (independent of the elements) such that if $g \in H^*$, $g^t \in N^*$.

Thus, by powering, we can assume that $\beta_i \in N^*$. Let U_i, V_i be disjoint open neighborhoods of $\partial\beta_i$ such that:

1. $\overline{U_i}, \overline{V_i} \subset \text{Int}(C)$;
2. $\overline{U_i} \cup \overline{V_i}$ is disjoint from $\overline{U_t} \cup \overline{V_t}$ for $1 \leq i \neq t \leq n$;
3. $\gamma_i U_i \cup \gamma_i V_i$ is disjoint from $U_i \cup V_i$ (see Figure 2.24).

By powering the (U_i, V_i) can be made absorbing for β_i .

Claim (1). Let $\varphi_i = \beta_i \gamma_i \beta_i$. Then (U_i, V_i) is absorbing for φ_i

Proof of Claim 1. Let $p \in S^2 \setminus V_i$. Then $\varphi_i(p) = \beta_i \gamma_i \beta_i(p) \in \beta_i \gamma_i(U_i)$. By (3), $\gamma_i U_i$ is disjoint from V_i . Applying β_i , we get $\varphi_i(p) \in U_i$, hence the absorbing property for β_i . \square

The key point that finishes the proof of Theorem 2.23 is the following:

Claim (2). Let $A = \langle N, \varphi_1, \dots, \varphi_n \rangle$. Let $X = \overline{U_1} \cup \overline{V_1} \cup \dots \cup \overline{U_n} \cup \overline{V_n}$. Then $\Lambda_A = \overline{(S^2 \setminus C)} \cup X \subsetneq S_\infty^2$.

Given this, we can apply the engulfing hypothesis to A , so there exists $K < \Gamma$ of finite index such that $K \supset A$. Hence $K \supset N$. The fact that $[\Gamma : K] < \infty$ implies that $K \supset N^*$; but then from $\beta_1, \dots, \beta_n \in N^*$, it follows that $\gamma_1, \dots, \gamma_n \in K$. Consequently, $K = \Gamma$. This contradiction finishes the proof of the theorem. \square

Proof of Claim 2. The limit set Λ_A is determined by orbits of points $z \in S_\infty^2$. We will consider the orbit of a point $p \in C \setminus X$ under the action of A . If w is a non-trivial word in A , then $w = n_1 f_1 \dots n_t f_t$ where $n_i \in N$ and $f_i \in \langle \varphi_1, \dots, \varphi_n \rangle$ with $n_i, f_i \neq 1$ apart from possibly n_1 and f_t . Assume $f_t \neq 1$. By the absorbing property for φ_i 's we see that points in $S_\infty^2 \setminus X$ are moved into $U_1 \cup V_1 \cup \dots \cup U_n \cup V_n$. Hence $f_t(p) \in U_1 \cup V_1 \cup \dots \cup U_n \cup V_n \subset C$ and $n_t f_t(p) \in n_t(C)$, which is disjoint from C . By the above, $f_{t-1} n_t f_t(p)$ is moved back into $U_1 \cup V_1 \cup \dots \cup U_n \cup V_n$. Continuing in this fashion, we can conclude that the image of a point is moved out of C or into $U_1 \cup \dots \cup U_n$, i.e. only accumulation points lie in X . \square

Exercise. Run this argument for negatively curved (resp. quasi-convex) groups.

Another application of extensions:

Theorem 2.24. *Let Γ be a group. Then Γ is RF if and only if for all cyclic subgroups $C < \Gamma$ there is at least one nontrivial extension of $C \rightarrow \mathbb{Z}/k\mathbb{Z}$ to a finite index subgroup of Γ .*

Proof. Assuming the extension property, let $g \in \Gamma \setminus \{1\}$. Then $\langle g \rangle$ is a cyclic subgroup. Then there exists $\varphi : \langle g \rangle \rightarrow \langle g \rangle / \langle g^k \rangle$ that extends to $V \xrightarrow{\varphi} \mathbb{Z}/k\mathbb{Z}$, $[\Gamma : V] < \infty$. Then $\text{Ker } \bar{\varphi}$ has finite index in Γ and $g \notin \text{ker } \bar{\varphi}$.

For the converse, let $C = \langle g \rangle$, $g \neq 1$. Since Γ is RF, there exists a normal subgroup of finite index N in Γ such that $g \notin N$. Consider $N \cdot \langle g \rangle$. We have

$$\frac{N \cdot \langle g \rangle}{N} \cong \frac{\langle g \rangle}{\langle g^k \rangle} \cong \mathbb{Z}/k\mathbb{Z}$$

for some $k > 1$. Then $\langle g \rangle \rightarrow \langle g \rangle / \langle g^k \rangle$ is the requiring map extending upwards. □

We next mention an application of Jaco's result (Theorem 2.13).

Let $Q = \mathbb{H}^3/\Gamma$ be a closed orientable hyperbolic 3-orbifold, i.e. Γ contains non-trivial elements of finite order. Finite subgroups of $\text{PSL}_2(\mathbb{C})$ are well understood. These are:

- Cyclic;
- Dihedral;
- A_4, S_4, A_5 .

\mathbb{H}^3/Γ is topologically a 3-manifold, but the geometry has singular points. Let $|Q|$ be the underlying 3-manifold.

Example. The exterior of a knot K in S^3 can be used as the basis for constructing a 3-orbifold. Instead of considering the 3-manifold which is the complement $S^3 \setminus K$, let K be the locus of singular points for the orbifold Q . We specify the cone angle along K by labelling K with an integer m which represents an angle of $\frac{2\pi}{m}$ along K (see Figure 2.25).

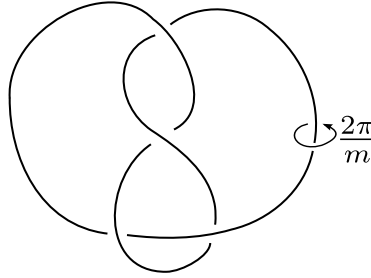

Figure 2.25: The orbifold with cone angle $\frac{2\pi}{m}$ along the figure-eight knot

In general, we can take as our singular locus a trivalent graph, as long as the labels at a vertex respect some rules which reflect the limited list of finite subgroups of $\text{PSL}_2(\mathbb{C})$ (see Figure 2.26).

Fact: Let N denote the normal closure in Γ of the elliptic elements. Then $\pi_1(|Q|) = \Gamma/N$.

Theorem 2.25. *Let Q be as above, and assume that $\pi_1(|Q|)$ is infinite. Suppose that Q contains an essential 2-orbifold Σ with $|\Sigma| \cong S^2$ or T^2 . If M is a 3-manifold commensurable with Q , then M is virtually Haken.*

In this setting, saying $\Sigma \subset Q$ is an essential 2-orbifold means that there exists $F \subset \Gamma$ with $F \cong F_0$, where F_0 is a Fuchsian group with $\mathbb{H}^2/F_0 \cong \Sigma$.

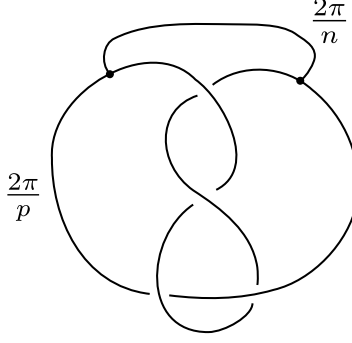

Figure 2.26: An orbifold with singular locus a trivalent graph

Proof. Let the orbifold group of Σ , $F \subset \Gamma$, be as above. Let $\varphi : \Gamma \rightarrow \Gamma/N \cong \pi_1(|Q|)$ where N is the normal closure of the elliptic elements. Note that $\pi_1(|Q|)$ is infinite and RF.

Case 1: $|\Sigma| = S^2$.

In this case, F is generated by elliptic elements. Hence $\varphi(F) = 1$. If $\Gamma_0 < \Gamma$ is torsion free and of finite index, then $F_0 = F \cap \Gamma_0$ is a surface group of genus $g \geq 2$. Moreover, $\varphi(F_0) = 1$. By RF, F_0 is contained in infinitely many subgroups of finite index. Hence \mathbb{H}^3/Γ_0 and M are virtually Haken.

Case 2: $|\Sigma| = T^2$.

In this case, $\varphi(F)$ is abelian.

(Window) Finitely generated abelian subgroups of $\pi_1(M^3)$ are $1, \mathbb{Z}, \mathbb{Z} \oplus \mathbb{Z}, \mathbb{Z}/n\mathbb{Z}, \mathbb{Z} \oplus (\mathbb{Z}/2\mathbb{Z})$ and \mathbb{Z}^3 . [See Hempel's 3-manifolds]

In our case, $\pi_1(|Q|)$ cannot be \mathbb{Z}^3 and $\mathbb{Z} \oplus (\mathbb{Z}/2\mathbb{Z})$ is ruled out by orientability. The key observation is that abelian subgroups are separable, and so we can run the argument in case 1. \square

3 Non-Compact, Finite Volume, Hyperbolic 3-Manifolds

In this section $M = \mathbb{H}^3/\Gamma$ will be a non-compact, finite volume, orientable hyperbolic 3-manifold. In an abuse of notation, M will denote both the compact manifold with boundary and also its interior. Previously, we have seen that “half lives, half dies” gives us a lower bound on $b_1(M)$ when M has boundary. Namely, we know that $b_1(\partial M)/2 \leq b_1(M)$. This immediately tells us that $b_1(M) > 0$, and we can prove even more.

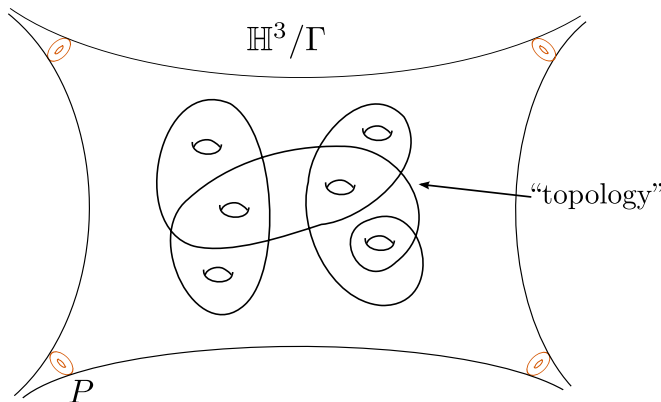

Figure 3.1: \mathbb{H}^3/Γ has finitely many finite volume cusps

Theorem 3.1. *Let M be as above, then $vb_1(M) = \infty$.*

Proof. The idea of the proof is to find finite covers, M_n , of M where the number of boundary components becomes arbitrarily large. Henceforth, we will denote the number of boundary component of M_n by $|\partial M_n|$. In order to complete the proof we will need the following lemma

Lemma 3.2. *Let M be as above, then M has a finite cover N where $|\partial N| \geq 3$.*

We prove Lemma 3.2 below. Using Lemma 3.2, we can assume that $|\partial M| \geq 3$. Let $P \subset \partial M$ be a boundary component and let $\partial_- M = \partial M \setminus P$. Consider the inclusion $\iota : \partial_- M \rightarrow M$, which induces $\iota_* : H_1(\partial_- M) \rightarrow H_1(M)$.

Exercise. If we let $K = \text{Ker } \iota_*$, then “half lives, half dies” gives us that $\text{rk}_{\mathbb{Q}}(K) \geq \frac{b_1(\partial M)}{2} - b_1(P)$.

Thus we see that K has rank at least 1, and so we let α be a non-trivial, primitive element of K . The cycle α gives rise to an embedded, non-separating surface $S \subset M$ such that $[\partial S] = \alpha$. The surface S also has the property that it is disjoint from P . The intersection pairing with S gives a surjection from $\pi_1(M)$ to \mathbb{Z} , and reducing mod n gives us a family of maps $\varphi_n : \pi_1(M) \rightarrow \mathbb{Z}/n\mathbb{Z}$.

$$\begin{array}{ccccc} & & \varphi_n & & \\ & \searrow & \curvearrowright & \searrow & \\ \pi_1 M & \longrightarrow & \mathbb{Z} & \longrightarrow & \mathbb{Z}/n\mathbb{Z} \end{array}$$

Let M_n be the cover of M corresponding to the kernel of φ_n . Since P is disjoint from S we see that P lifts to all of these covers and that $|\partial M_n| \geq n$. Applying “half lives, half dies” completes the proof.

Proof of Lemma 3.2. Let T be a boundary component of M , let $x \in \Gamma \setminus \pi_1 T$ be a hyperbolic element, and let $m \in \pi_1 T \setminus 1$. Since x^k has the same fixed point set as x for $k \neq 0$ and the fixed point set of x is disjoint from the fixed point set of $\pi_1 T$, we know that $x^k \notin \pi_1 T$ for any $k \neq 0$. Next, let $y = [x^2, m]$, and observe that by the previous comment on fixed points that $y \neq 1$. By residual finiteness we know that there exists a

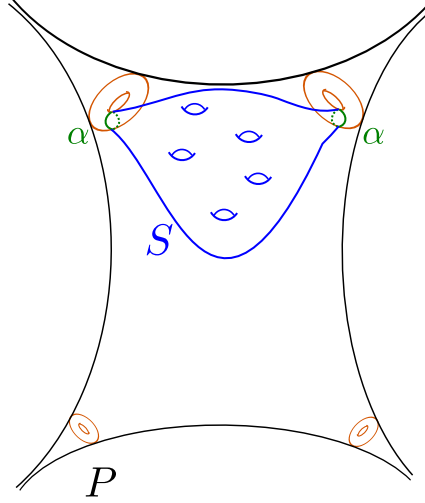

Figure 3.2: The surface $S \subset M$ is embedded and non-separating, with $[\partial S] = \alpha$

surjection $\varphi : \Gamma \rightarrow G$ where $|G| < \infty$ and $\varphi(y) \neq 1$. The proof will be completed by showing that the cover corresponding to the kernel of φ has at least three boundary components.

Let M_φ be the aforementioned cover and suppose for contradiction that $|\partial M_\varphi| \leq 2$, then by covering space theory we know that $|G : \varphi(\pi_1 T)| \leq 2$. By index considerations we know that $\varphi(x^2) = \varphi(x)^2$ is contained in $\varphi(\pi_1 T)$. Since $\varphi(\pi_1 T)$ is abelian we have that $\varphi(y) = \varphi([x^2, m]) = [\varphi(x^2), \varphi(m)] = 1$, which is a contradiction. \square

\square

Now that we know that $vb_1(m) = \infty$, a natural question is whether it also has large fundamental group. In the presence of boundary the answer is yes.

Theorem 3.3. *Let M be as above. Then $\pi_1 M$ is large.*

Proof. Start by replacing M by a finite cover with at least 3 boundary components, which we will still call M . Let M_n be the cyclic n -fold cover of M given in the proof of Theorem 3.1 and let S_0, S_1, \dots, S_{n-1} be the lifts of S to M_n . Let $F_n = S_0 \cup S_{[n/2]}$, and observe that since the topology of F_n is independent of n that $b_1(F_n)$ is bounded independent of n . Next, let A_n^1 and A_n^2 be the compact 3-manifold components of $M_n \setminus F_n$. Since the number of boundary components becomes arbitrarily large we see that as $n \rightarrow \infty$, $b_1(A_n^j) \rightarrow \infty$ for $j = 1, 2$.

Next, let $\partial_0(A_n^j) = \partial(A_n^j) \setminus F_n$. Let $\iota_* : H_1(\partial_0(A_n^j)) \rightarrow H_1(A_n^j)$ be the map induced by inclusion and let $K = \text{Ker } \iota_*$. Another application of “half lives, half dies” combined with the previous comments about the growth of betti numbers allows us to construct non-separating embedded surfaces, W_n^1 and W_n^2 , in A_n^1 and A_n^2 respectively, that are disjoint from F_n (see Figure 3.3). Finally, since the union of W_n^1 and W_n^2 are non-separating we can apply homework 3.1 to get a retraction to a wedge of circles and conclude that $\pi_1(M)$ is large. \square

Remark. The statement of HW3 Q1 has the hypothesis incompressible, but in the context of the above proof, it suffices to be properly embedded.

Remark. Cooper–Long–Reid use the ideas above to show the following.

Theorem. *If M is as above, then there exists a closed surface Σ of genus $g \geq 2$ and a map $f : \Sigma \looparrowright M$ such that $f_* : \pi_1 \Sigma \rightarrow \pi_1 M$ is injective.*

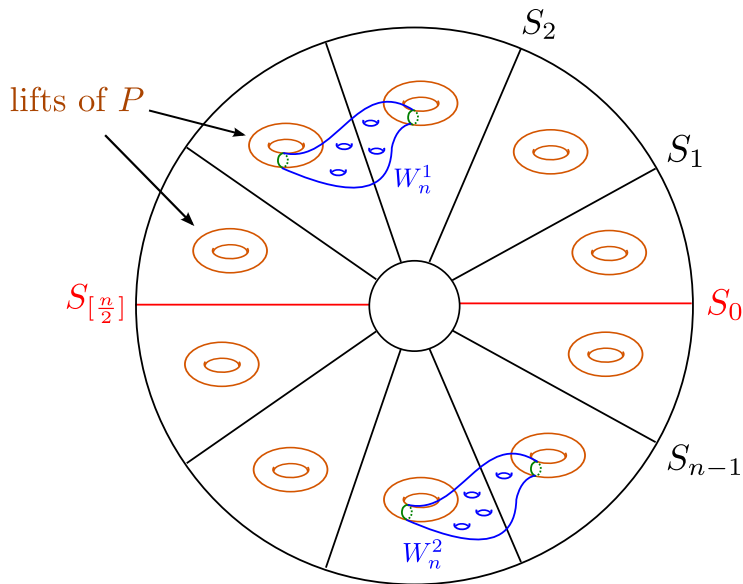

Figure 3.3: The surfaces S_0 and $S_{[\frac{n}{2}]}$ together separate M_n

The proof follows the plan outlined in the proof above, but instead of finite cyclic covers, it takes the infinite cyclic cover (see Figure 3.4).

Here $X = M \setminus N(S)$, $M_\Sigma = \bigcup_{-\infty}^{\infty} X_i$ where each piece X_i is homeomorphic to X . Denote by Y_n the union $\bigcup_{i=1}^n X_i$ of n pieces. We construct a closed surface $G_n \subset Y_n$ by joining two preimages of S by annuli, as shown in Figure 3.4. The idea now is that when one tries to compress away G_n in M_S , one finds that, for sufficiently large n , the torus preimages of P preclude this.

Let Σ be the image of G_n under the projection map. We note that the representation $\rho : \pi_1 \Sigma \rightarrow \mathrm{PSL}_2 \mathbb{C}$ carries an accidental parabolic element (see Figure 3.5). This is a typical feature of such constructions, as the following theorem demonstrates.

Theorem (Menasco). *Let $L \subset S^3$ be an alternating, hyperbolic link. Then any closed embedded incompressible surface carries an accidental parabolic that maps to a meridian.*

Exercise. (for knot theorists) Find a surface in 8_{17} with an accidental parabolic.

If M is a finite volume, hyperbolic 3-manifold and $\Sigma \subset M$ is a π_1 -injective surface of genus at least 2, then one of two things can happen:

1. Σ has accidental parabolics;
2. The image of $\pi_1(\Sigma)$ in $\pi_1(M)$ is quasi-fuchsian (its limit set is a Jordan curve).

This dichotomy prompts the following conjecture by Menasco and Reid:

Conjecture. (Menasco–Reid) Let $K \subset S^3$ be hyperbolic, then $S^3 \setminus K$ does not contain any closed, embedded, totally geodesic surfaces.

Here is a slightly stronger version.

Conjecture. There exist knots K such that $S^3 \setminus K$ contains a separating, totally geodesic, embedded surface.

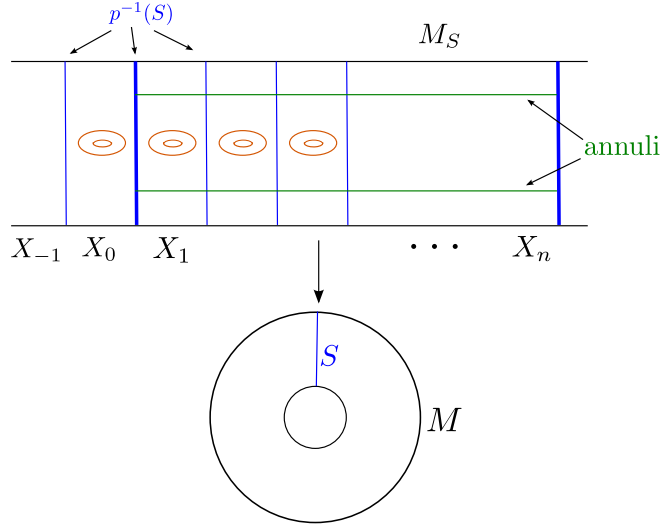

Figure 3.4: The surface G_n is two copies of S connected by annuli

There do, however, exist non-separating totally geodesic surfaces, which we construct as follows.

Example. We will construct totally geodesic Seifert surfaces of some knots by using rigid sub 2-orbifolds. Let p, q, r be positive integers with $p \leq q \leq r$ (it is possible that $r = \infty$), and let $\Delta(p, q, r)$ be the group generated by reflections in the faces of a hyperbolic triangle with angles $\frac{2\pi}{p}, \frac{2\pi}{q}, \frac{2\pi}{r}$ (if $r = \infty$ then the triangle will have an ideal vertex). Next, let Γ be the index 2 subgroup of orientation preserving elements of $\Delta(p, q, r)$. The group $\Gamma(p, q, r)$ has a presentation given by $\langle a, b \mid a^p = b^q = (ab)^r = 1 \rangle$ (when $r = \infty$ the third relation is omitted). If we insist that the quotient has finite coarea then the triangle group $\Delta(p, q, \infty)$ can be represented in $\text{PSL}_2(\mathbb{C})$ in one way up to conjugation. By conjugating we can choose our representation ρ such that

$$a \mapsto \begin{pmatrix} \lambda & 1 \\ 0 & \lambda^{-1} \end{pmatrix}, b \mapsto \begin{pmatrix} \mu & 0 \\ s & \mu^{-1} \end{pmatrix},$$

where $\lambda + \lambda^{-1} = 2 \cos(\frac{2\pi}{p})$ and $\mu + \mu^{-1} = 2 \cos(\frac{2\pi}{q})$. In order for this representation to be discrete,

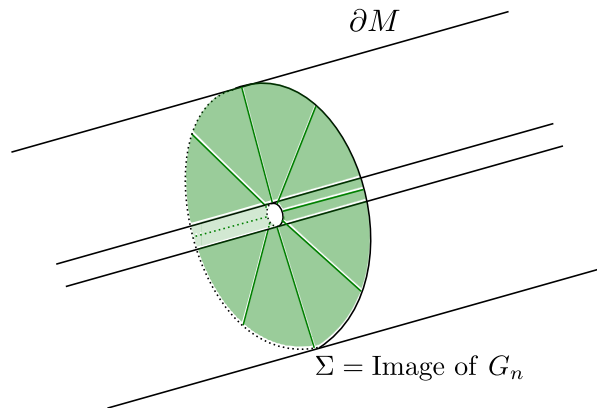

Figure 3.5: The required surface Σ is the projection of G_n

faithful, and finite coarea we need ab to be parabolic (i.e. $\text{tr}^2 \rho(ab) = 4$). A simple computation shows that $\text{tr}(ab) = \lambda\mu + s + \lambda^{-1}\mu^{-1}$. Since there are only finitely many primitive p th and q th roots of unity, we see that only finitely many (in fact only one) s can solve $\text{tr}^2 \rho(ab) = 4$. The goal is now to build 3-orbifolds with rigid sub 2-orbifolds that are covered by $S^3 \setminus K$. For more details see [Neumann–Reid] in Math Annalen.

Exercise. If $\Gamma \subset \text{SL}_2(\mathbb{C})$ and $\text{tr}(\gamma) \in \mathbb{R}$ for each $\gamma \in \Gamma$ then Γ is conjugate into either $\text{SL}_2(\mathbb{R})$ or $\text{SU}_2(\mathbb{C})$. Hence, $\Delta(p, q, r)$ is always Fuchsian.

One way to look at the above examples is to find or construct 3-orbifolds with rigid sub-2-orbifolds and which cover knot complements $S^3 \setminus K$.

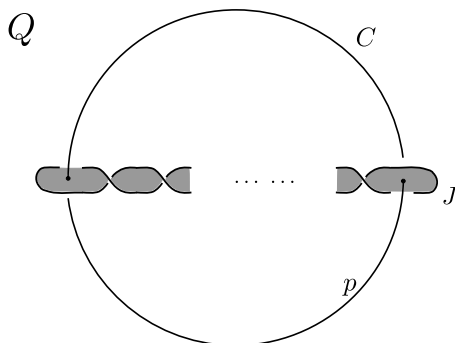

Figure 3.6: The curve J is the boundary of a disk D which meets C in two points

Let Q denote the orbifold with base space S^3 and singular locus as shown in Figure 3.6. Let D be the disk bounded by the curve J . Then D meets the unknotted component C in two points. We label both C and J with an integer $p \geq 3$, giving a (p, p, ∞) sub-orbifold of Q . Taking the p -fold cover of Q which unbranches C gives the pretzel knot given in Figure 3.7; here the disk D lifts to the pictured Seifert surface.

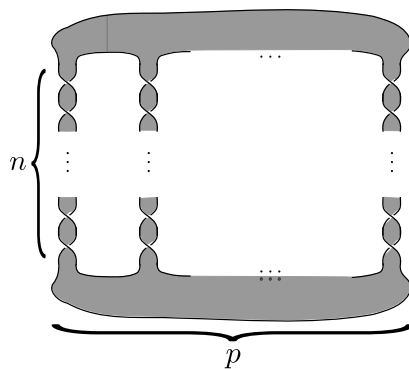

Figure 3.7: D lifts to a Seifert surface

When we have both $p \geq 3$ and $n \geq 3$, these knots are hyperbolic. Hence, the respective surfaces are totally geodesic.

Previously, we have seen that if X has at least three boundary components then we could find a non-separating surface, S , that connected two of the boundary components and missed a third. Furthermore, we used S to construct cyclic covers X_n , dual to S , that contained a pair of surfaces whose union was non-separating, which in turn proved that $\pi_1(X)$ was large. These ideas can be used in certain cases to prove that certain closed 3-orbifolds are large.

Let X be $M \setminus L$, where L is a link with at least 3 components and let Q be the orbifold with underlying space M and singular locus L with labels n where n is a positive integer. There exists a surjection $\psi : \pi_1(X) \twoheadrightarrow \pi_1^{orb}(Q)$ given by killing the subgroup normally generated by the n th powers of the meridians of L . Additionally, since $X \subset Q$ we can extend each of the X_n to a Q_n so that Q_n is an n -fold cyclic cover of Q . For large values of n we have seen that we can find a map $\pi_1(X_n) \rightarrow \mathbb{Z} * \mathbb{Z}$. There is also a natural map from $\mathbb{Z} * \mathbb{Z}$ to $\mathbb{Z}/n\mathbb{Z} * \mathbb{Z}/n\mathbb{Z}$ given by killing the normal closure of the generators of each factor. Call the composition of these two maps φ_n . When $n \geq 3$, $\mathbb{Z}/n\mathbb{Z} * \mathbb{Z}/n\mathbb{Z}$ is large, and so if we could find $\tilde{\varphi}_n$ such that $\tilde{\varphi}_n \circ \psi = \varphi_n$ then we would have shown that Q is large.

$$\begin{array}{ccccc}
 & & \varphi_n & & \\
 & \curvearrowright & & \curvearrowleft & \\
 \pi_1 X_n & \longrightarrow & \mathbb{Z} * \mathbb{Z} & \longrightarrow & \mathbb{Z}/n\mathbb{Z} * \mathbb{Z}/n\mathbb{Z} \\
 & \searrow \psi & & \nearrow \tilde{\varphi}_n & \\
 & & \pi_1^{orb} Q_n & &
 \end{array}$$

Exercise. Let $\mu_1, \mu_2, \dots, \mu_k$ be the meridians of X and verify that $\langle \langle \mu_1^n, \mu_2^n, \dots, \mu_k^n \rangle \rangle \leq \text{Ker } \varphi_n$. Show why this implies that $\tilde{\varphi}_n$ exists.

Using this argument we have the following applications.

Theorem 3.4. *Let $Q = \mathbb{H}^3/\Gamma$ be an orbifold with singular locus a link $L \subset M$ with at least 3 components, and each meridian of L has order n in Γ . Then for large n , Γ is large.*

Theorem 3.5. *Let K be a hyperbolic knot and $m \geq 2$ be an integer. Then for all sufficiently large n , the mn -fold cyclic branched cover of S^3 branched over K is large.*

Definition. Given a knot complement $M = S^3 \setminus K$ and an integer $k \in \mathbb{N}$, the k -fold cyclic branched cover of M is obtained as follows: let μ be a meridian of K . Consider the k -fold cyclic cover M_k corresponding to the group $\langle \mu^k \rangle$. Then perform Dehn filling on the meridian μ^k of M_k .

Before starting the proof of Theorem 3.5 we will discuss covers of S^3 branched over knots. One way to define such a cover is to start by taking n -fold cyclic cover of $S^3 \setminus K$. By performing $(1, 0)$ Dehn filling on the boundary, we get the n -fold cover of S^3 branched over K .

Alternatively, We can let Q be the orbifold with base space S^3 and singular locus K labelled with n . There is a unique normal subgroup, H , of $\pi_1^{orb}(Q)$ such that $\pi_1^{orb}(Q)/H \cong \mathbb{Z}/n\mathbb{Z}$. The cover corresponding to this subgroup is the n -fold cover of S^3 branched over K .

Proof of Theorem 3.5. The proof will rely on the following consequence of the Orbifold Theorem.

Theorem. *The k -fold cover of S^3 branched over a hyperbolic knot, K , is hyperbolic when $k \geq 3$ unless K is the figure eight knot, in which case k must be at least 4. Furthermore, when $k = 3$, the 3-fold cover of S^3 branched over the figure eight knot is Euclidean.*

Given the previous result Theorem 3.5 follows from the following.

Proposition 3.6. *Let M be a compact, orientable manifold, $K \subset M$ be a knot, and let m be a positive integer. Let $Q(K, m)$ be the orbifold with base space M and singular locus K labelled with m . If there exists $\varphi : \pi_1^{orb}(Q(K, m)) \twoheadrightarrow H$ where $|H| < \infty$ such that $|H : \varphi(\langle [K] \rangle)| \geq 3m$, then for all sufficiently large n , $\pi_1^{orb}(Q(K, mn))$ is large.*

The following Lemma tells us that under certain circumstances we can guarantee the existence of such homomorphisms.

Lemma 3.7. *If Γ is Kleinian and of finite covolume or a 3-dimensional Euclidean orbifold group, then a homomorphism as in Proposition 3.6 always exists.*

□

Proof of Proposition 3.6. First note that $\text{Ker } \varphi$ determines a finite cover \tilde{Q} of $Q(K, m)$. The hypothesis on the index gives that the preimage $L \subset \tilde{Q}$ of K has at least 3 components. We further note that there exists a cover $Q(K, mn) \rightarrow Q(K, m)$, branched over K , from which we get a corresponding cover $\tilde{Q}_n \rightarrow \tilde{Q}$.

$$\begin{array}{ccc} \tilde{Q} & \longleftarrow & \tilde{Q}_n \\ \downarrow & & \downarrow \text{finite} \\ Q(K, m) & \longleftarrow & Q(K, mn) \end{array}$$

Now notice that the singular locus of \tilde{Q} has label $q \geq 1$, and so Theorem 3.4 yields that if n is taken to be sufficiently large, then $\pi_1^{\text{orb}}(\tilde{Q}_n)$ is large. Hence, $\pi_1^{\text{orb}}(Q(K, mn))$ is large for such n . □

Proof of Lemma 3.7. We start with the case that $Q = \mathbb{H}^3/\Gamma$ for a finite covolume Kleinian group Γ . We will prove the following claim.

Claim. *Given any $g \in \Gamma \setminus \{1\}$, and integer $N \geq 1$, there exists a map $\varphi : \Gamma \rightarrow G$, with $|G| < \infty$, such that $|G : \langle \varphi(g) \rangle| \geq N$.*

We make use of the following theorem. Recall that a field k is called a *number field* if $[k : \mathbb{Q}] < \infty$.

Theorem 3.8. *The group $\Gamma < \text{PSL}_2(\mathbb{C})$ can be conjugated into $\text{PSL}_2(k)$, where k is a number field.*

We defer the proof, and use this result to prove Lemma 3.7. We assume we have conjugated Γ to lie inside $\text{PSL}_2(k)$. Let R_k denote the ring of algebraic integer in k . Recall [Window] that every ideal $I \subset R_k$ can be expressed as a product $I = \mathcal{P}_1^{a_1} \dots \mathcal{P}_s^{a_s}$, where $\mathcal{P}_i \subset R_k$ is a prime ideal, and $a_i \in \mathbb{N}$. Consider an arbitrary element $\begin{pmatrix} a & b \\ c & d \end{pmatrix} \in \Gamma$. One of the entries could have some non-trivial denominator x , i.e. there exists a prime ideal \mathcal{P} of R_k such that $\mathcal{P} \mid \langle x \rangle$. We can find a finite collection \mathcal{S} of prime ideals of R_k such that $\Gamma < \text{PSL}_2(R_k[\mathcal{S}])$, where $R_k[\mathcal{S}]$ denotes the ring with those ideals in \mathcal{S} inverted. Now the prime ideals of R_k which do not belong to \mathcal{S} define prime ideals of $R_k[\mathcal{S}]$. For $\mathcal{P} \notin \mathcal{S}$, we can define the natural reduction map

$$\text{PSL}_2(R_k[\mathcal{S}]) \xrightarrow{\varphi_{\mathcal{P}}} \text{PSL}_2(R_k[\mathcal{S}]/\mathcal{P}) \cong \text{PSL}_2(\mathbb{F}_p).$$

By density theory for prime in number fields, there exist infinitely many prime ideals $\mathcal{P} \subset R_k$ such that $R_k/\mathcal{P} \cong \mathbb{F}_p$. Such \mathcal{P} are called *split* primes. Hence, we have infinitely many reduction homomorphisms $\varphi_{\mathcal{P}} : \Gamma \rightarrow \text{PSL}_2(\mathbb{F}_p)$, where we assume $p \neq 2$. Then $\langle \varphi_{\mathcal{P}}(g) \rangle$ is a cyclic subgroup of $\text{PSL}_2(\mathbb{F}_p)$. Note that $|\text{PSL}_2(\mathbb{F}_p)| = \frac{p(p^2 - 1)}{2}$. Furthermore, the structure theory for subgroups of $\text{PSL}_2(\mathbb{F}_p)$ says that, if $H < \text{PSL}_2(\mathbb{F}_p)$, then:

1. H is cyclic of order p , or cyclic of order n dividing $\frac{p \pm 1}{2}$;
2. H is dihedral of order $2n$, with n as above;
3. H is a semi-direct product of a cyclic group of order p and cyclic group of order $\frac{p-1}{2}$; or
4. $H \cong A_4, S_4, A_5$.

In case 1, $\langle \varphi_{\mathcal{P}}(g) \rangle$ has index at least $\frac{p^2 - 1}{2}$. So, choosing p so that this index is at least N , we would be done.

Claim. $\varphi_{\mathcal{P}}$ *surjects for infinitely many prime ideals \mathcal{P} .*

Proof of Claim. Suppose $\varphi_{\mathcal{P}}$ does not surject for the prime ideal \mathcal{P} . Γ is not solvable, so let us choose $\alpha \in \Gamma \setminus \{1\}$ lying very deep in the solvability series for Γ . Suppose also that $\varphi_{\mathcal{P}}(g), \varphi_{\mathcal{P}}(\alpha) \neq 1$ under reduction via \mathcal{P} . Since homomorphisms preserve solvability series, and $\varphi_{\mathcal{P}}(\alpha) \neq 1$, we see that $\varphi_{\mathcal{P}}(\Gamma)$ cannot be any group in 1, 2, or 3 above, or be isomorphic to A_4 or S_4 . Hence, we can assume that $\varphi_{\mathcal{P}}(\Gamma) \cong A_5$. But then, since Γ is finite generated, infinitely many kernels $\text{Ker } \varphi_{\mathcal{P}}$ coincide. Thus there exist elements of Γ that are trivial under infinitely many reduction homomorphisms. This is a contradiction, since every ideal has finitely many prime divisors. \square

We now turn to the general Kleinian group case. Suppose Γ is a non-elementary, finitely generated Kleinian group, with $Q = \mathbb{H}^3/\Gamma$. If $\Gamma < \text{PSL}_2(k)$ for a number field k , we may argue as above. If not, Γ could be geometrically infinite; in this case, Thurston's Hyperbolization Theorem gives a Kleinian group $\Gamma' \cong \Gamma$ such that Γ' is geometrically finite. Then Deformation theory (using circle packings, cf. Brooks) produces a finite covolume Kleinian group Δ and a subgroup $\Gamma'' < \Delta$ such that $\Gamma'' \cong \Gamma' \cong \Gamma$. \square

Proof of Theorem 3.8. We will abuse notation and work in $\text{SL}_2(\mathbb{C})$. It suffices to prove the theorem for Γ torsion-free: if Γ has torsion, it has a torsion-free subgroup of finite index, so each $\gamma \in \Gamma$ has the property that $\gamma^N \in \text{PSL}_2(k)$ for some N , so the entries of γ are algebraic. We think of Γ embedded inside $\text{SL}_2(\mathbb{C})$. Let the *representation variety* of Γ be

$$\text{Hom}(\Gamma, \text{SL}_2(\mathbb{C})) = \{\rho \mid \rho : \Gamma \rightarrow \text{SL}_2(\mathbb{C}) \text{ is a homomorphism}\}.$$

Fix a generating set $\Gamma = \langle \gamma_1, \dots, \gamma_n \rangle$. Then, for each i , write

$$\rho(\gamma_i) = A_i = \begin{pmatrix} a_i & b_i \\ c_i & d_i \end{pmatrix},$$

where each entry belongs to \mathbb{C} , and $a_i d_i - b_i c_i = 1$. Let $R_1 = \dots = R_m = 1$ denote the relations of Γ . Evaluating $R_j(A_1, \dots, A_n) = I$, for each $j = 1, \dots, m$, determines polynomial equations in the entries a_i, b_i, c_i, d_i ; that is, $\text{Hom}(\Gamma, \text{SL}_2(\mathbb{C}))$ is an algebraic set. Conjugate Γ and consider the subset of representatives where

- A_1 fixes 0 and ∞ , so $b_1 = c_1 = 0$, and $A_1 = \begin{pmatrix} a_1 & 0 \\ 0 & d_1 \end{pmatrix}$;
- A_2 fixes 1, so $A_2 = \begin{pmatrix} a_2 & b_2 \\ c_2 & d_2 \end{pmatrix}$ with $a_2 + b_2 = c_2 + d_2$.

In addition, the manifold \mathbb{H}^3/Γ may have cusps C_1, \dots, C_t which determine conjugacy classes of parabolic subgroups $\langle u_i, v_i \rangle \cong \mathbb{Z} \oplus \mathbb{Z}$. To deal with this, we insist the representations satisfy $\text{tr}^2(u_i) - 4 = 0$, $\text{tr}^2(v_i) - 4 = 0$, and $u_i v_i = v_i u_i$. Let $V(\Gamma)$ be this subset of $\text{Hom}(\Gamma, \text{SL}_2(\mathbb{C}))$ (or, more precisely, the component of $V(\Gamma)$ containing the identity). Note that at present, everything is defined over \mathbb{Q} .

Claim. $\dim(V(\Gamma)) = 0$.

Exercise. if V is an algebraic variety, define over a number field k , and $\dim(V) = 0$, then V is a point, and its coordinates are algebraic numbers.

Proof of Claim. We use rigidity. Suppose that $\dim(V(\Gamma)) > 0$. Local rigidity (Weil, Garland) tells us that for $\rho \in V(\Gamma)$ sufficiently close to the identity, ρ is an isomorphism and $\rho(\Gamma)$ has finite covolume. Now, by Mostow rigidity, we know that $\rho(\Gamma)$ is conjugate to Γ ; that is, there exists a $g \in \text{Isom}(\mathbb{H}^3)$ such that $g\rho(\Gamma)g^{-1} = \Gamma$. Then the fixed-point normalization which we imposed on A_1 and A_2 gives only finitely many possibilities. \square

\square

We can use the above conjugation of Γ into some $\text{PSL}_2(k)$ to get an invariant of \mathbb{H}^3/Γ .

Definition. Define the *trace field* $\mathbb{Q}(\text{tr } \Gamma)$ of Γ to be the extension $\mathbb{Q}(\text{tr } \gamma \mid \gamma \in \Gamma)$.

The above discussion shows that $\mathbb{Q}(\text{tr } \Gamma)$ is a number field, and by Mostow rigidity, it is an invariant of Γ , and hence of the manifold \mathbb{H}^3/Γ . Note that $\mathbb{Q}(\text{tr } \Gamma) \not\subseteq \mathbb{R}$, since the quotient has finite volume.

Question. Which number fields k ($\not\subseteq \mathbb{R}$) arise as $\mathbb{Q}(\text{tr } \Gamma)$ for Γ Kleinian of finite covolume?

Conjecture. Every such number field k does arise in this way.

Example 1. Let K be the figure-eight knot. Then $S^3 \setminus K = \mathbb{H}^3/\Gamma$, where $\Gamma \subset \text{PSL}_2(\mathbb{Z}[\omega])$ is generated by

$$\Gamma = \left\langle \begin{pmatrix} 1 & 1 \\ 0 & 1 \end{pmatrix}, \begin{pmatrix} 1 & 0 \\ \omega & 1 \end{pmatrix} \right\rangle,$$

and $\omega^2 + \omega + 1 = 0$. Here $\mathbb{Z}[\omega] \subseteq \mathbb{Q}(\sqrt{-3})$ is the ring of integers, and so in this case we have $\mathbb{Q}(\text{tr } \Gamma) = \mathbb{Q}(\sqrt{-3})$.

Example 2. Let d be a square-free positive integer and let \mathcal{O}_d be the ring of integers in $\mathbb{Q}(\sqrt{-d})$. Then the *Bianchi groups* $\text{PSL}_2(\mathcal{O}_d)$ are all Kleinian groups of finite covolume, with trace fields $\mathbb{Q}(\sqrt{-d})$.

Example 3. Let M_W be the Weeks manifold, described as the Dehn filling of the Whitehead link given in Figure 3.8. This is known to be the smallest volume hyperbolic 3-manifold (with volume approximately 0.9427...). We have $H_1(M_W) \cong \mathbb{Z}/5\mathbb{Z} \oplus \mathbb{Z}/5\mathbb{Z}$.

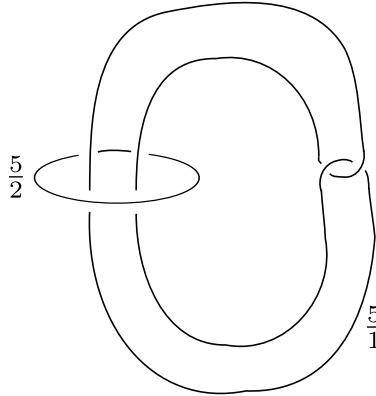

Figure 3.8: The Weeks manifold M_W

Let $\rho : \pi_1 M_W \rightarrow \text{PSL}_2(\mathbb{C})$ be a faithful discrete representation. It is possible to show (for example via SnapPea) that

$$\pi_1 M_W = \langle a, b \mid a^2 b^2 a^2 b^{-1} a b^{-1}, a^2 b^2 a^{-1} b a^{-1} b^2 \rangle.$$

Consider an arbitrary representation $\rho : \pi_1 M_W \rightarrow \text{SL}_2(\mathbb{C})$ where we conjugate so that

$$\rho(a) = \begin{pmatrix} x & 1 \\ 0 & x^{-1} \end{pmatrix}, \rho(b) = \begin{pmatrix} y & 0 \\ r & y^{-1} \end{pmatrix}.$$

We are only interested in such representations that are irreducible. Taking the first relation and evaluating on $\rho(a), \rho(b)$, we find that assuming $r \neq 0$, then $r = \frac{x^2 - x + y^2 - xy^2}{xy}$. Now, taking this value for r and reworking the first relation gives $p(x, y) = 0$ where

$$p(x, y) = 1 + x^2 + y^2 - xy^2 + x^2 y^2 + y^4 + x^2 y^4.$$

Now take the second relation and evaluate at $\rho(a), \rho(b)$ (with r as above). We get that $(x - y)(-1 + xy) = 0$, from which we conclude that either $x = y$ or $x = \frac{1}{y}$. Setting $x = y$ gives a polynomial for x and we get that $p(x) = x^6 + 2x^4 - x^3 + 2x^2 + 1$. Now, setting $z = x + x^{-1}$, the trace of $\rho(a)$, then z satisfies $z^3 - z - 1 = 0$. One also finds that $r = 2 - z$. Note that the real root of $z^3 - z - 1 = 0$, which is approximately 1.32, is inadmissible. We invoke the key fact that for two-generator groups, $\mathbb{Q}(\text{tr } \Gamma) = \mathbb{Q}(\text{tr } a, \text{tr } b, \text{tr } ab)$; that is, every trace $\text{tr } \gamma$ is a polynomial in $\text{tr } a, \text{tr } b$ and $\text{tr } ab$ with coefficients in \mathbb{Z} . Using this, we find that $\mathbb{Q}(\text{tr } \Gamma_W) = \mathbb{Q}(z)$ for z a complex root of $z^3 - z - 1$.

Example 4. Recall from earlier the Seifert-Weber dodecahedral space \mathbb{H}^3/Γ_S . In this case, it turns out that $\mathbb{Q}(\text{tr } \Gamma_S) = \mathbb{Q}(\sqrt{-1 - 2\sqrt{5}})$.

Before we proceed, we note that one way of producing orbifolds with more complicated trace fields is as follows. Each Bianchi group $\text{PSL}_2(\mathcal{O}_d)$ contains the modular group $\text{PSL}_2(\mathbb{Z})$. Thus we see the inclusion

$$M = \mathbb{H}^2/\text{PSL}_2(\mathbb{Z}) \looparrowright \mathbb{H}^3/\text{PSL}_2(\mathcal{O}_d) = Q_d.$$

By the LERF property, and passage to a finite-sheeted cover Q'_d if necessary, we can suppose that the modular surface M is embedded and non-separating in Q'_d . Then if $d \neq d'$, cutting along M in Q'_d and $Q'_{d'}$ results in two orbifolds with boundary components M which can be identified (see Figure 3.9). If the

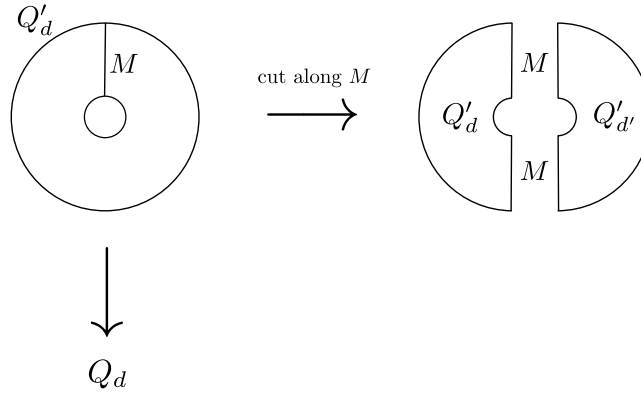

Figure 3.9: The construction of new orbifolds out of Bianchi orbifolds

resulting space is $X = \mathbb{H}^3/\Gamma$, then one can show that $\mathbb{Q}(\text{tr } \Gamma) = \mathbb{Q}(\sqrt{-d}, \sqrt{-d'})$.

We now return to the discussion of surfaces contained in hyperbolic 3-manifolds.

Theorem 3.9. *There are closed hyperbolic 3-manifolds without totally geodesic surfaces.*

Proof. We aim to show that the Weeks manifold M_W above has no such surface. In fact, we will demonstrate that Γ_W has no purely hyperbolic elements. Let $M_W = \mathbb{H}^3/\Gamma_W$ and assume for the sake of contradiction that $\gamma \in \Gamma_W$ is purely hyperbolic; that is, $\text{tr } \gamma \in \mathbb{R}$ and $|\text{tr } \gamma| > 2$. We know from Example 3 above that $\text{tr } \gamma \in \mathbb{Q}(\text{tr } \Gamma_W) = k = \mathbb{Q}(z)$. It follows that $\text{tr } \gamma \in k \cap \mathbb{R} = \mathbb{Q}$. In fact we can say more: it turns out that $\text{tr } \gamma \in R_k \cap \mathbb{Q} = \mathbb{Z}$. Recall that above we had three irreducible representations of Γ_W corresponding to the three roots of $z^3 - z - 1$, namely $\rho_0, \bar{\rho}_0$, and $\rho_{\mathbb{R}}$, where $\rho_{\mathbb{R}}$ denotes the real representation.

Exercise. Show that the image $\text{Im } \rho_{\mathbb{R}} \subseteq \text{SU}(2)$.

These representations are all faithful Galois conjugates of ρ_0 . We have that $\text{Im } \rho_0 \subset M_2(k(x))$. We therefore ask what $\text{tr } \rho_{\mathbb{R}}(\delta)$ looks like for some $\delta \in \Gamma_W$. Since $\text{Im } \rho_{\mathbb{R}} \subset \text{SU}(2)$, it follows that $|\text{tr } \rho_{\mathbb{R}}(\delta)| \leq 2$ for every $\delta \in \Gamma_W$. If $\sigma : k \rightarrow \mathbb{R}$ is the real embedding of k , then $\sigma(\text{tr } \delta) = \text{tr } \rho_{\mathbb{R}}(\delta)$ for each $\delta \in \Gamma$. So, for γ as above, we have $|\sigma(\text{tr } \gamma)| = |\text{id}(\text{tr } \gamma)| = |\text{tr } \gamma| > 2$, a contradiction. \square

We now turn our attention to the same question in the non-compact case. We are particularly interested in manifolds with torus boundary, and when surfaces survive under the operation of Dehn surgery on boundary tori.

Let $M = \mathbb{H}^3/\Gamma$ be cusped and of finite volume. Let $f : S \looparrowright M$ with S a closed, orientable surface of genus $g \geq 2$ and f_* being π_1 -injective. Then $f_*(\pi_1 S) \subset \Gamma$ is geometrically finite in Γ , so $f_*(\pi_1 S)$ either

- has accidental parabolics; or
- is quasi-Fuchsian.

Surfaces falling into the second of these cases have good survival properties under Dehn surgery, as the following sample result demonstrates.

Theorem 3.10. *Let M be as above, with one cusp, and $S \looparrowright M$ totally geodesic. Then for all but finitely many Dehn surgeries α , S remains incompressible in $M(\alpha)$.*

Proof. Choose a horospherical cusp torus T such that $S \subseteq M \setminus T$. The key point is the 2π -Theorem [Window] of Gromov–Thurston.

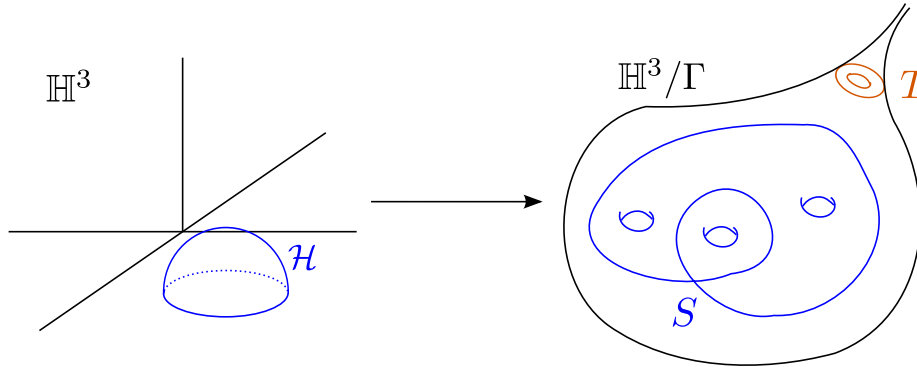

Figure 3.10: $f_*(\pi_1 S)$ acts on the plane $\mathcal{H} \subset \mathbb{H}^3$

Theorem (2π -Theorem, Gromov–Thurston). *Let M and T be as above, and let $\alpha \subset T$ be an essential simple closed curve. If the length $\ell_T(\alpha) > 2\pi$, then $M(\alpha)$ admits a metric of negative curvature.*

The incompressibility of S in $M(\alpha)$ is guaranteed by the construction of this negatively curved metric. The metric on $M(\alpha)$ (see Figure 3.11) is the hyperbolic metric on M together with a choice of negative curved metric on V so that the result is negatively curved. \square

- Exercise.** (1) The preimages of S are hemispheres with centers in \mathbb{C} (rather than vertical planes);
(2) There exists an upper bound on the radius of these hemispheres.

In order to optimize the number of surgeries we will exclude, we seek to push the horosphere \mathcal{H} based at ∞ as low as possible without intersecting other preimages. Recall that the length of the slope β in the horosphere of height t is $\frac{\ell_{\mathbb{H}^3}(\beta)}{t}$ (see Figure 3.12).

Remark. We can replace the assumption that M has one cusp with multiple cusps, with the same conclusion: the surface S survives except possibly in a finite number of surgeries.

Many examples of this will come from the *Bianchi orbifolds* $\mathbb{H}^3/\mathrm{PSL}_2(\mathcal{O}_d)$, where d is a square-free positive integer, and \mathcal{O}_d is the ring of integers of the quadratic imaginary number field $\mathbb{Q}(\sqrt{-d})$.

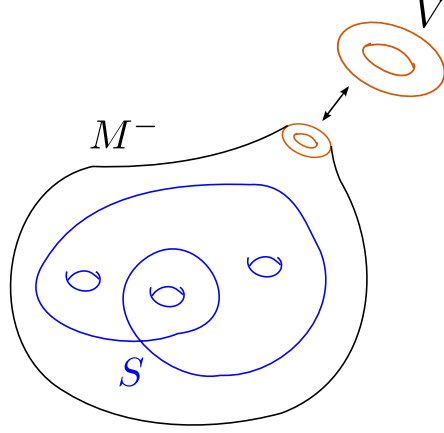

Figure 3.11: The curve $\alpha \subset \partial M^-$ is identified with the meridian of the solid torus V

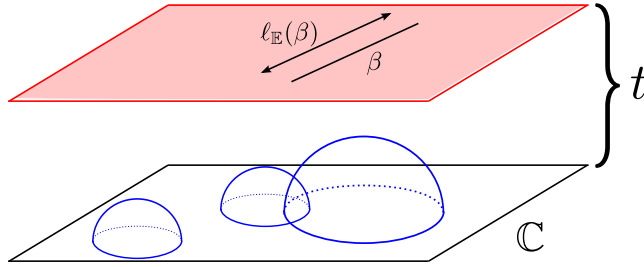

Figure 3.12: The length of the curve β varies with the height of the horosphere t

Theorem 3.11. *The Bianchi groups $\mathrm{PSL}_2(\mathcal{O}_d)$ (resp. orbifolds $\mathbb{H}^3/\mathrm{PSL}_2(\mathcal{O}_d)$) contain “many” cocompact Fuchsian subgroups (resp. closed totally geodesic sub-2-orbifolds).*

Corollary 3.12. *If $\Gamma < \mathrm{PSL}_2(\mathcal{O}_d)$ is torsion-free and of finite index, then \mathbb{H}^3/Γ contains “many” closed totally geodesic surfaces.*

Example. Let K be the figure-eight knot. Then $S^3 \setminus K$ covers an orbifold $Q_3 = \mathbb{H}^3/\mathrm{PSL}_2(\mathcal{O}_3)$. We further see that $S^3 \setminus K = \mathbb{H}^3/\Gamma$, where

$$\Gamma = \left\langle \begin{pmatrix} 1 & 1 \\ 0 & 1 \end{pmatrix}, \begin{pmatrix} 1 & 0 \\ \omega & 1 \end{pmatrix} \right\rangle$$

and $\omega^2 + \omega + 1 = 0$. Here the first generator $a = \begin{pmatrix} 1 & 1 \\ 0 & 1 \end{pmatrix}$ represents the meridian of the torus boundary, and

$l = \begin{pmatrix} 1 & 2\sqrt{-3} \\ 0 & 1 \end{pmatrix}$ represents the corresponding longitude. We may construct cocompact Fuchsian subgroups of $\mathrm{PSL}_2(\mathcal{O}_3)$ as follows. Let $\mathcal{C}_D = \{z \in \mathbb{C} \mid |z|^2 = D\}$.

We will see later that

$$\mathrm{Stab}^{(+)}(\mathcal{C}_2, \mathrm{PSL}_2(\mathcal{O}_3)) = \{\gamma \in \mathrm{PSL}_2(\mathcal{O}_3) \mid \gamma\mathcal{C}_2 = \mathcal{C}_2 \text{ and } \gamma \text{ preserves the components of } \mathbb{C} \setminus \mathcal{C}_2\}$$

is a cocompact Fuchsian group. Hence, $\Gamma \cap \mathrm{Stab}^{+}(\mathcal{C}_2, \mathrm{PSL}_2(\mathcal{O}_3))$ is a surface subgroup of Γ . One checks directly that if $T \in \mathrm{PSL}_2(\mathcal{O}_3)$, then $T\mathcal{C}_2 = \mathcal{C}$, a circle in $\hat{\mathbb{C}}$ which has equation

$$a|z|^2 + Bz + \overline{B}\overline{z} + c = 0$$

where $a, c \in \mathbb{Z}$ and $B \in \mathcal{O}_3$. This circle has radius $\frac{\sqrt{2}}{|a|}$, from which we see that the heights of the hemispheres are bounded above by $\sqrt{2}$. In order to examine surgery slopes, we push a horosphere based at ∞ down to a height $\sqrt{2} + \epsilon$, where $\epsilon > 0$. Here, the length of a surgery curve β is $\frac{\ell_{\mathbb{E}}(\beta)}{\sqrt{2} + \epsilon}$. By the 2π Theorem, we seek those curves such that

$$\frac{\ell_{\mathbb{E}}(\beta)^2}{(\sqrt{2} + \epsilon)^2} \geq 4\pi^2.$$

Let $\beta = a^p l^q = \begin{pmatrix} 1 & p + 2q\sqrt{-3} \\ 0 & 1 \end{pmatrix}$. Then this inequality becomes

$$\frac{p^2 + 12q^2}{(\sqrt{2} + \epsilon)^2} \geq 4\pi^2 \quad (*)$$

If we set $\epsilon = \frac{1}{10}$, we find that $(*)$ holds when $|q| = 1$ and $|p| > 8$, when $|q| = 2$ and $|p| > 6$, and for any p when $|q| \geq 3$.

These facts are summarized in the following result:

Corollary 3.13. *For the figure-eight knot K , $(S^3 \setminus K)(\frac{p}{q})$ contains a π_1 -injective surface, except possibly when*

$$\pm \frac{p}{q} \in \left\{ \frac{1}{0}, \frac{0}{1}, \frac{1}{1}, \frac{2}{1}, \frac{3}{1}, \frac{4}{1}, \frac{5}{1}, \frac{6}{1}, \frac{7}{1}, \frac{8}{1}, \frac{1}{2}, \frac{3}{2}, \frac{5}{2} \right\}.$$

Remark. Of these exceptional surgery slopes, it is known that:

- $\frac{0}{1}$ gives back S^3 ;
- $\frac{0}{1}$ and $\frac{4}{1}$ are Haken;
- $\frac{1}{1}$, $\frac{2}{1}$ and $\frac{3}{1}$ are Seifert Fiber Spaces; and
- the remainder are hyperbolic. In this case, one can check (for example by using computer algebra programs) that these contain surface subgroups.

Example. Let W denote the Whitehead link in S^3 . It is known that $S^3 \setminus W$ covers the orbifold Q_1 , with degree 12. We also see that $\frac{1}{n}$ -Dehn surgery on the unknot component produces the twist knot with n full twists. As in the case of the figure-eight knot, we find that $\text{Stab}(\mathcal{C}_3, \text{PSL}_2(\mathcal{O}_1))$ is a cocompact Fuchsian subgroup. Thus, for sufficiently large n , the complement of the twist knot with n full twists contains a π_1 -injective surface.

Remark. We have the following theorem regarding the two examples discussed above.

Theorem. *The figure-eight knot K and the Whitehead link W are universal; i.e. every closed, orientable 3-manifold is a branched cover of S^3 branched over K or W .*

That is, given any 3-manifold M , there exists a link $L \subset M$ such that $M \setminus L$ is a branched cover of Q_1 or Q_3 . This theorem looks useful, but has not as yet been used in a productive way.

We now return to the proofs of the above results.

Proof of 3.11. We first require some number-theoretic constructions. Let d and D be positive integers, with d square-free. Define $A = A(d, D)$ to be the quaternion algebra (4-dimensional central simple algebra) over \mathbb{Q} with basis $\{1, i, j, ij\}$ and where multiplication is defined by

$$i^2 = -d, \quad j^2 = D, \quad ij = -ji.$$

If $x \in A$ is given by $x = x_0 + x_1i + x_2j + x_3ij$, we define $\bar{x} = x_0 - x_1i - x_2j - x_3ij$ to be the conjugate of x in A . We have two standard homomorphisms $A \rightarrow \mathbb{Q}$ given by

$$\mathrm{tr}(x) = x + \bar{x} = 2x_0; \quad (\text{trace})$$

$$n(x) = x\bar{x} = x_0^2 + dx_1^2 - Dx_2^2 - dDx_3^2. \quad (\text{norm form})$$

Next, letting $M_2(R)$ denote the set of 2-by-2 matrices with entries in R , we define $\rho : A \rightarrow M_2(\mathbb{Q}(\sqrt{-d}))$ by

$$\rho(x_0 + x_1i + x_2j + x_3ij) = \begin{pmatrix} x_0 + x_1\sqrt{-d} & D(x_2 + x_3\sqrt{-d}) \\ x_2 - x_3\sqrt{-d} & x_0 - x_1\sqrt{-d} \end{pmatrix}.$$

Since each $x_i \in \mathbb{Q}$, and by simplicity, we see $\rho(A) \cong M_2(\mathbb{Q}(\sqrt{-d}))$. Next, define the order $\mathcal{O} = \mathbb{Z}[1, i, j, ij] \subset A$ to be the subset of A with integer co-ordinates. It follows that $\rho(\mathcal{O}) \subset M_2(\mathcal{O}_d)$. Further, we let

$$\mathcal{O}^1 = \{x \in \mathcal{O} \mid n(x) = 1\}$$

and observe that since ρ preserves the respective norms on A and M_2 , we have that $\rho(\mathcal{O}^1) \subset \mathrm{SL}_2(\mathcal{O}_d)$. Hence, $\rho(\mathcal{O}^1)$ is discrete. Furthermore, we see that because ρ also preserves traces, the traces of elements of $\rho(\mathcal{O}^1)$ are rational integers. This leads us to conclude that $\rho(\mathcal{O}^1)$ is a Fuchsian group.

Claim (1). *For infinitely many choices of D , $\rho(\mathcal{O}^1)$ is a cocompact Fuchsian group.*

Note that “infinitely many” can be made more precise: the requirement is that D be such that $n(x) = 0$ if and only if $x = 0$. One consequence of assuming this is that D is not a perfect square; for simplicity, we will henceforth assume that D is square-free.

Proof of Claim (1). We define a conjugate representation $\sigma : A \rightarrow M_2(\mathbb{R})$ of ρ as follows: for $x \in A$, let g_x be given by

$$g_x = \sigma(x_0 + x_1i + x_2j + x_3ij) = \begin{pmatrix} x_0 + x_1\sqrt{D} & x_2 + x_3\sqrt{D} \\ -d(x_2 - x_3\sqrt{D}) & x_0 - x_1\sqrt{D} \end{pmatrix}.$$

We seek to show that $\mathbb{H}^3/\sigma(\mathcal{O}^1)$ is closed. By the above discussion, it suffices to show that $\sigma(\mathcal{O}^1)\backslash\mathrm{SL}_2(\mathbb{R})$ is compact.

More precisely, we seek to prove that for every $g \in \mathrm{SL}_2(\mathbb{R})$, there exists $x \in \mathcal{O}^1$ such that $g_x g \in K$, where K is a fixed compact set. We first show the following claim.

Claim (2). *For a given $g \in \mathrm{SL}_2(\mathbb{R})$, there exists $x \in \mathcal{O}$, with $x \neq 0$, such that $g_x g \in K$ for a fixed compact set of matrices K . Moreover, K has the form $K = \cup D_m$, where D_m is a compact set of matrices of determinant m , and the union is taken over finitely many integers m .*

We first assume Claim (2) and thereby prove Claim (1). Define an equivalence relation \sim on \mathcal{O} by setting $x \sim y$ if and only if $x^{-1}y \in \mathcal{O}^1$.

Key Fact: The elements of \mathcal{O} of fixed norm lie in finitely many equivalence classes.

Given this fact, the argument proceeds as follows. Let $g \in \mathrm{SL}_2(\mathbb{R})$, and let $0 \neq x \in \mathcal{O}$ be an element given by Claim (2) such that $g_x g \in K$. Let $m = n(x) \neq 0$. Now choose x_i as in the Fact, so $x_i x \in \mathcal{O}^1$. Consider

$$g_{x_i^{-1}x} g = g_{x_i^{-1}} g_x g \in g_{x_i^{-1}} K,$$

where K is a fixed compact set. Now we note that there are finitely many equivalence classes, and we are done. \square

Proof of Claim (2). Note that for $g \in \mathrm{SL}_2(\mathbb{R})$, and $x \in \mathcal{O}$, we have that $\det(g_x g) = m \neq 0$. Let $g = \begin{pmatrix} \alpha & \beta \\ \gamma & \delta \end{pmatrix}$ and consider

$$\begin{aligned} g_x g &= \begin{pmatrix} x_0 + x_1\sqrt{D} & x_2 + x_3\sqrt{D} \\ -d(x_2 - x_3\sqrt{D}) & x_0 - x_1\sqrt{D} \end{pmatrix} \begin{pmatrix} \alpha & \beta \\ \gamma & \delta \end{pmatrix} \\ &= \begin{pmatrix} \alpha x_0 + \alpha x_1\sqrt{D} + \gamma x_2 + \gamma x_3\sqrt{D} & \beta x_0 + \beta x_1\sqrt{D} + \delta x_2 + \delta x_3\sqrt{D} \\ -\alpha d(x_2 - x_3\sqrt{D}) + \gamma x_0 - \gamma x_1\sqrt{D} & -\beta d(x_2 - x_3\sqrt{D}) + \delta x_0 - \delta x_1\sqrt{D} \end{pmatrix} \\ &= \begin{pmatrix} l_{11} & l_{12} \\ l_{21} & l_{22} \end{pmatrix}. \end{aligned}$$

Recall that here each $x_i \in \mathbb{Z}$, and d and D are fixed integers. The four entries l_{ij} are linear forms in these variables which determine a lattice in \mathbb{R}^4 . Also recall that a lattice $L \subset \mathbb{R}^n$ consists of points $(x_1, x_2, \dots, x_n) \in \mathbb{R}^n$ such that $x_i = \sum_{j=1}^n x_{ij} n_j$, where the $n_j \in \mathbb{Z}$ vary and the $x_{ij} \in \mathbb{R}$ are fixed. If A denotes the associated n -by- n matrix, then the *volume* of L is then $\mathrm{vol}(L) = |\det(A)|$. In the case at hand, we have that the volume of the lattice is $\Delta = 4dD$.

Now let c_{11}, c_{12}, c_{21} and c_{22} be positive constants such that $\prod c_{ij} = \Delta$ and $|d_{ij}| \leq c_{ij}$. This determines a parallelepiped $P \subset \mathbb{R}^4$ which is closed, convex, and symmetric about 0. We have that $\mathrm{vol}(P) = 2^4 \Delta$. We now need Minkowski's Lemma.

Theorem (Minkowski's Lemma). *Let $L \subset \mathbb{R}^n$ be a lattice, and assume $M = \mathrm{vol}(L) \neq 0$. Suppose that P is a closed, convex subset of \mathbb{R}^n , symmetric about 0, whose volume is $\mathrm{vol}(P) \geq 2^n M$. Then there exists a non-zero point of L which lies in P .*

We apply this to the present situation, and find x_0, x_1, x_2 and $x_3 \in \mathbb{Z}$ such that $g_x g \in P$. Notice that, by compactness of P , if $g \in P$, then $|\det(g)| < N$ for some sufficiently large N ; moreover, this N is universal, i.e. if $\det(g_x) = m$, then $\det(g_x g) < N$. Thus $m < N$. From this observation, it follows that we may take

$$D_m = \{g \in P \mid \det(g) = m\}$$

for those m with $|m| < N$. Each D_m is compact, and $g_x g \in \bigcup_{|m| < N} D_m$ as required. This completes the proof of Claim (2), and hence of Theorem 3.11. \square

\square

Example. Recall the example of the figure-eight knot complement $S^3 \setminus K$. It was claimed that the set of elements which stabilize the circle centered at the origin and of radius $\sqrt{2}$ formed a cocompact Fuchsian subgroup of $\pi_1(S^3 \setminus K)$. Let $A = \left(\frac{-3, 2}{\mathbb{Q}}\right)$, with norm form $n(x) = x_0^2 + 3x_1^2 - 2x_2^2 - 6x_3^2$. We verify that this quaternion algebra meets the hypotheses of the above results.

Suppose that there exists $x \in A \setminus \{0\}$ such that $n(x) = 0$; that is, suppose there exist rational numbers $a_0, a_1, a_2, a_3 \in \mathbb{Q}$ such that

$$a_0^2 + 3a_1^2 - 2a_2^2 - 6a_3^2 = 0.$$

By clearing denominators, we may assume that in fact each $a_i \in \mathbb{Z}$. If we reduce the equation modulo 3, it becomes

$$a_0^2 - 2a_2^2 \equiv 0 \pmod{3}.$$

A non-zero solution to this would imply the existence of an x with the property that $x^2 \equiv 2 \pmod{3}$, a contradiction. Notice that if $a_0 = a_2 = 0$, then we have the same situation with a_1 and a_3 . Thus we see that in A , $n(x) = 0$ if and only if $x = 0$.

Example. In the case of the Whitehead link complement, where the circle chosen had radius $\sqrt{3}$, the quaternion algebra has symbol $\left(\frac{-1, 3}{\mathbb{Q}}\right)$. Here, a similar argument to the above works to check that $n(x) = 0$ if and only if $x = 0$. In this way, we find ‘‘many’’ examples of cocompact Fuchsian subgroups corresponding to quaternion algebras where $n(x) = 0$ if and only if $x = 0$.

We now remark that this method can also be used to produce finite coarea Fuchsian subgroups of the Bianchi groups. Suppose a circle $\mathcal{C} \subset \mathbb{C}$ is defined by $a|z|^2 + Bz + \bar{B}\bar{z} + C = 0$, with $a, c \in \mathbb{Z}$, $a \neq 0$, and $B \in \mathcal{O}_d$. Then $F_{\mathcal{C}} = \text{Stab}(\mathcal{C}, \text{PSL}_2(\mathcal{O}_d))$ determines a finite coarea Fuchsian group.

To see this, recall that we have seen that $F_D = \text{Stab}(\mathcal{C}_D, \text{PSL}_2(\mathcal{O}_d))$ is a finite coarea Fuchsian group, where \mathcal{C}_D has center the origin and radius \sqrt{D} . Let $T = \begin{pmatrix} a & \bar{B} \\ 0 & 1 \end{pmatrix} \in \text{PGL}_2(\mathbb{Q}(\sqrt{-d}))$. One checks that $T\mathcal{C} = \mathcal{C}_D$, and hence that

$$T^{-1} \text{Stab}(\mathcal{C}_D, \text{PSL}_2(\mathbb{C})) T = \text{Stab}(\mathcal{C}, \text{PSL}_2(\mathbb{C})).$$

With this in mind, we seek to relate $T^{-1} F_D T$ with $F_{\mathcal{C}}$. We first note that the groups $T^{-1} \text{PSL}_2(\mathcal{O}_d) T$ and $\text{PSL}_2(\mathcal{O}_d)$ are commensurable. To see this, let $A = \langle a \rangle \subset \mathbb{Z}$ be the cyclic subgroup of \mathbb{Z} generated by a , and $a_1, a_2, a_3, a_4 \in A$ such that

$$\begin{pmatrix} 1 + a_1 & a_2 \\ a_3 & 1 + a_4 \end{pmatrix} \in \Gamma(a) < \text{PSL}_2(\mathbb{Z})$$

is an element of the principal congruence subgroup of level a . We then find

$$\begin{aligned} \begin{pmatrix} \frac{1}{a} & -\frac{\bar{B}}{a} \\ 0 & 1 \end{pmatrix} \begin{pmatrix} 1 + a_1 & a_2 \\ a_3 & 1 + a_4 \end{pmatrix} \begin{pmatrix} a & \bar{B} \\ 0 & 1 \end{pmatrix} &= \begin{pmatrix} \frac{1+a_1}{a} - \frac{\bar{B}a_3}{a} & \frac{a_2}{a} - \frac{\bar{B}(1+a_4)}{a} \\ a_3 & 1 + a_4 \end{pmatrix} \begin{pmatrix} a & \bar{B} \\ 0 & 1 \end{pmatrix} \\ &= \begin{pmatrix} 1 + a_1 - \bar{B}a_3 & \frac{1}{a}(\bar{B} + \bar{B}a_1 - \bar{B}^2 a_3 + a_2 - \bar{B} - \bar{B}a_4) \\ aa_3 & a_3\bar{B} + 1 + a_4 \end{pmatrix} \\ &= \begin{pmatrix} 1 + a_1 - \bar{B}a_3 & \frac{1}{a}(\bar{B}a_1 - \bar{B}^2 a_3 + a_2 - \bar{B}a_4) \\ aa_3 & a_3\bar{B} + 1 + a_4 \end{pmatrix} \in \text{PSL}_2(\mathcal{O}_d) \end{aligned}$$

as a divides each of the a_i . We now have the following diagram.

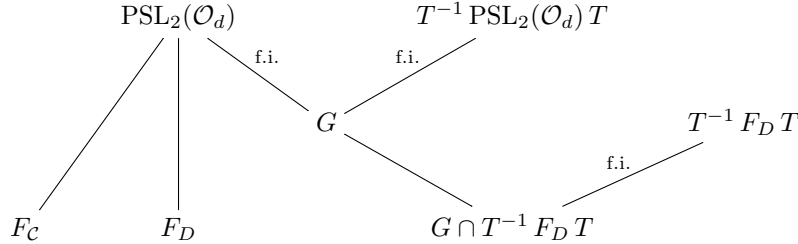

We remark that $F_{\mathcal{C}} \supset G \cap T^{-1} F_D T$, from which we see that $F_{\mathcal{C}}$ is cocompact / of finite coarea.

We close by noting that Margulis characterized arithmetic lattices $\Gamma < \text{PSL}_2(\mathbb{C})$ by using the notion of the commensurator

$$\text{Comm}(\Gamma) = \{g \in \text{PSL}_2(\mathbb{C}) \mid g\Gamma g^{-1} \text{ is commensurable with } \Gamma\}.$$

This characterization is that Γ is arithmetic if and only if $\text{Comm}(\Gamma)$ is dense in $\text{PSL}_2(\mathbb{C})$ (with respect to the topology induced from \mathbb{C}^4), and that Γ is non-arithmetic if and only if $[\text{Comm}(\Gamma) : \Gamma] < \infty$. In practice, one can also use the fact that $\text{Comm}(\Gamma)$ contains the normalizer $N(\text{PSL}_2(\mathbb{C}), \Gamma)$ of Γ in $\text{PSL}_2(\mathbb{C})$.